

User Manual

Washing  
Machine

## CONTENTS

Safety information	2	Before first use	10
Safety instructions	3	Daily use	10
Product description	5	Hints and tips	13
Control panel	5	Care and cleaning	14
Programme Chart	6	Troubleshooting	16
Consumption values	8	Technical Data	18
Options	9	Installation	19
Settings	10		

Subject to change without notice.

## SAFETY INFORMATION

Before the installation and use of the appliance, carefully read the supplied instructions. The manufacturer is not responsible for any injuries or damages that are the result of incorrect installation or usage. Always keep the instructions in a safe and accessible location for future reference.

### **Children and vulnerable people safety**

- This appliance can be used by children aged from 8 years and above and persons with reduced physical, sensory or mental capabilities or lack of experience and knowledge if they have been given supervision or instruction concerning the use of the appliance in a safe way and understand the hazards involved.
- Do not let children play with the appliance.
- Children aged 3 years and under must be kept away from this appliance when it is in operation at all times.
- Keep all packaging away from children and dispose of it appropriately.
- Keep detergents away from children.
- Keep children and pets away from the appliance when the door is open.
- Children shall not carry out cleaning and user maintenance of the appliance without supervision.

### **General Safety**

- Do not change the specification of this appliance.

- Do not exceed the maximum load of 7 kg (refer to the "Programme chart" chapter).
- The operating water pressure at the water entry point from the outlet connection must be between 0.5 bar (0.05 MPa) and 8 bar (0.8 MPa).
- The ventilation opening in the base (if applicable) must not be covered by a carpet, mat, or any floor covering.
- The appliance must be connected to the water mains using the new supplied hose sets, or other new hose sets supplied by the Authorised Service Centre.
- Old hose sets must not be reused.
- If the mains power supply cable is damaged, it must be replaced by the manufacturer, its Authorised Service Centre or similarly qualified persons to avoid an electrical hazard.
- Before any maintenance operation, deactivate the appliance and disconnect the mains plug from the socket.
- Do not use high pressure water sprays and/or steam to clean the appliance.
- Clean the appliance with a moist cloth. Use only neutral detergents. Do not use abrasive products, abrasive cleaning pads, solvents or metal objects.

## SAFETY INSTRUCTIONS

---

### Installation

- Remove all the packaging and the transit bolts.
- Keep the transit bolts in a safe place. If the appliance is to be moved in future they must be reattached to lock the drum to prevent internal damage.
- Always take care when moving the appliance as it is heavy. Always use safety gloves and enclosed footwear.
- Do not install or use a damaged appliance.
- Follow the installation instruction supplied with the appliance.
- Do not install or use the appliance where the temperature can be less than 0°C or where it is exposed to the weather.
- The floor area where the appliance is to be installed must be flat, stable, heat resistant and clean.
- Make sure that there is air circulation between the appliance and the floor.
- Adjust the feet to have the necessary space between the appliance and the flooring.
- Do not install the appliance where the appliance lid cannot be fully opened.
- Do not put a container to collect possible water leakage under the appliance. Contact the Authorised Service Centre to ensure which accessories can be used.

## Electrical connection

- The appliance must be earthed.
- Always use a correctly installed shockproof socket.
- Make sure that the parameters on the rating plate are compatible with the electrical ratings of the mains power supply.
- Do not use multi-plug adapters and extension cables.
- Make sure not to cause damage to the mains plug and to the mains cable. Should the mains cable need to be replaced, this must be carried out by our Authorised Service Centre.
- Connect the mains plug to the mains socket only at the end of the installation. Make sure that there is access to the mains plug after the installation.
- Do not touch the mains cable or the mains plug with wet hands.
- Do not pull the mains cable to disconnect the appliance. Always pull the mains plug.
- This appliance complies with the E.E.C. Directives.

## Water connection

- Do not cause damage to the water hoses.
- Before connection to new pipes, pipes not used for a long time, where repair work has been carried out or new devices fitted (water meters, etc.), let the water flow until it is clean and clear.
- Ensure that there are no visible water leaks during and after the first use of the appliance.

## Use



**WARNING!** Risk of injury, electrical shock, fire, burns or damage to the appliance.

- This appliance is for household use only.
- Follow the safety instructions on the detergent packaging.
- Do not put flammable products or items that are wet with flammable products in, near or on the appliance.
- Make sure that all metal objects are removed from the laundry.
- Do not wash fabrics which are heavily soiled with oil, grease or other greasy substances. It can damage rubber parts of the washing machine. Prewash such fabrics by hand before loading them into the washing machine.

## Service

- To repair the appliance contact an Authorised Service Centre.
- Use original spare parts only.

## Disposal



**WARNING!** Risk of injury or suffocation.

- Disconnect the appliance from the mains electrical and water supplies.
- Cut off the mains electrical cable close to the appliance and dispose of it.
- Remove the door catch to prevent children or pets from becoming trapped in the drum.
- Dispose of the appliance in accordance with local requirements for the disposal of Waste Electrical and Electronic Equipment (WEEE).

## PRODUCT DESCRIPTION

### Appliance overview

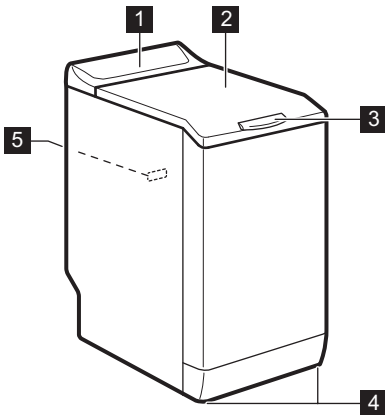

- 1** Control panel
- 2** Lid
- 3** Lid handle
- 4** Feet for levelling the appliance
- 5** Rating plate

## CONTROL PANEL

### Control panel description

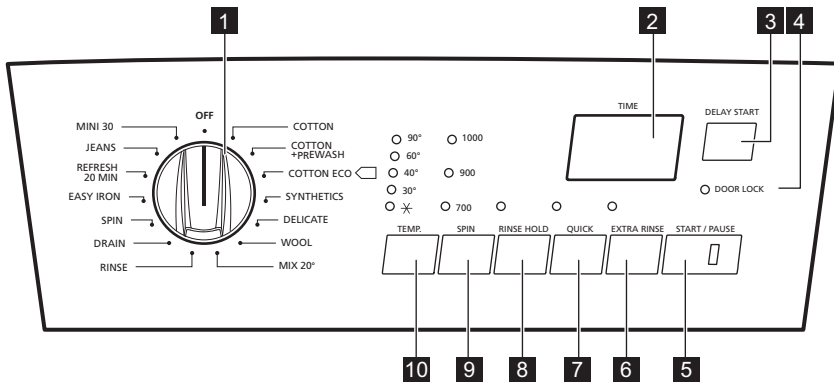

- 1** Programme knob
- 2** Display
- 3** DELAY START button
- 4** DOOR LOCK lid indicator
- 5** START/PAUSE button
- 6** EXTRA RINSE button
- 7** QUICK button
- 8** RINSE HOLD button

## 9 SPIN reduction button

### Display

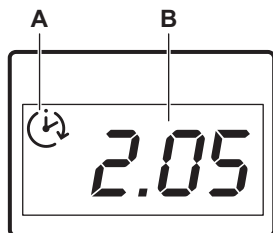

- **A**  
The delay start .  
When you press the delay start button, the display shows the delay start time.
- **B**

## 10 TEMPERATURE button

This area shows:

- 125 - Programme duration
- 0 - Programme is completed
- 2h - Delay start hours
- E20 - Alarm codes (refer to the chapter 'Troubleshooting')
- Err - Message of error. Incorrect option selection: the display shows this message for some seconds if:
  - You set a option that is not suitable for the programme.
  - You change the programme while it operates.

## PROGRAMME CHART

Programme Temperature range	Maximum load Maximum spin speed	Programme description (Type of load and soil level)
COTTON 90°C - Cold	7 kg 1000 rpm	<b>White cotton and coloured cotton.</b> Normal soil and light soil.
COTTON+ PREWASH 90°C - Cold	7 kg 1000 rpm	<b>White cotton and coloured cotton.</b> Heavy soil and normal soil.
 COTTON ECO <sup>1)</sup> 60°C - 40°C	7 kg 1000 rpm	<b>White cotton and fast-coloured cotton.</b> Normal soil. The energy consumption decreases and the time of the washing programme is extended.
SYNTHETICS 60°C - Cold	3 kg 1000 rpm	<b>Synthetic items or mixed fabric items.</b> Normal soil.
DELICATE 40°C - Cold	2,5 kg 700 rpm	<b>Delicate fabrics such as acrylics, viscose, polyester items.</b> Normal soil.
WOOL 40°C - Cold	1,5 kg 1000 rpm	<b>Machine washable wool, hand washable wool and delicate fabrics</b> with «hand washing» care symbol. <sup>2)</sup>

Programme Temperature range	Maximum load Maximum spin speed	Programme description (Type of load and soil level)
MIX 20° 20°C	2,5 kg 1000 rpm	Special programme for cotton, synthetic and mixed fabrics lightly soiled. Select this programme to reduce the energy consumption. Make sure that the detergent is suitable for low temperatures in order to have good washing results <sup>3)</sup> .
RINSE	2,5 kg 1000 rpm <sup>4)</sup>	To rinse and spin the laundry. <b>All fabrics</b> , except woollens and very delicate fabrics. Reduce the spin speed accordingly to the type of laundry.
DRAIN	7 kg	To drain the water in the drum. <b>All fabrics</b> .
SPIN	7 kg 1000 rpm	To spin the laundry and to drain the water in the drum. <b>All fabrics, except woollens and delicate fabrics</b> .
EASY IRON 60°C - Cold	1 kg 900 rpm	<b>Synthetic items requiring a gentle wash</b> . Normal and light soil. <sup>5)</sup>
REFRESH 20 MIN 30°C	1 kg 900 rpm	<b>Synthetic and delicate items</b> . Light soil items or items to refresh.
JEANS 60°C - Cold	3 kg 1000 rpm	<b>Items in denim and jersey</b> . Also for dark coloured items.
MINI 30 30°C	1 kg 700 rpm	A short cycle for <b>synthetic and delicate items with light soil level</b> or for items to freshen up.

<sup>1)</sup> **Standard programmes for the Energy Label consumption values.** According to regulation 1061/2010, these programmes are respectively the «Standard 60°C cotton programme» and the «Standard 40°C cotton programme». They are the most efficient programmes in terms of combined energy and water consumption for washing normally soiled cotton laundry.



The water temperature of the washing phase may differ from the temperature declared for the selected programme.

<sup>2)</sup> During this cycle the drum rotates slowly to ensure a gentle wash. It can seem that the drum doesn't rotate or doesn't rotate properly, but this is normal for this programme.

<sup>3)</sup> The appliance performs the short heating phase if the water temperature is below 20°C. The appliance can show the temperature setting as "cold".

<sup>4)</sup> The default spin speed is 700 rpm.

<sup>5)</sup> To reduce creasing, this cycle regulates the water temperature and performs a soft wash and spin phase. The appliance adds some rinses.

## Programme options compatibility

Programme	SPIN	RINSE HOLD	QUICK <sup>1)</sup>	EXTRA RINSE	DELAY START
COTTON	■	■	■	■	■
COTTON+ PREWASH	■	■	■	■	■
COTTON ECO 	■	■		■	■
SYNTHETICS	■	■	■	■	■
DELICATE		■	■	■	■
WOOL	■	■			■
MIX 20°	■	■		■	■
RINSE	■	■		■	■
DRAIN					■
SPIN	■				■
EASY IRON	■	■		■	■
REFRESH 20 MIN	■				■
JEANS	■	■			■
MINI 30					■

<sup>1)</sup> When you set this option, we recommend that you decrease the quantity of the laundry. It is possible to keep the full load but the washing results can be unsatisfactory. Recommended load: cotton: 3,5 kg, synthetics and delicates: 1,5 kg.

## CONSUMPTION VALUES



Stated values are obtained in laboratory conditions with relevant standards. Different causes can change the data: the quantity and type of laundry and ambient temperature. Water pressure, the supply voltage and the temperature of inlet water may also affect the washing programme duration.



Technical specifications may be changed without prior notice to improve the quality of product.



Programmes	Load (kg)	Energy consumption (kWh)	Water consumption (litre)	Approximate programme duration (minutes)	Remaining moisture (%) <sup>1)</sup>
COTTON 60°C	7	1,16	58	197	60
COTTON 40°C	7	0,61	56	192	60
SYNTHETICS 40°C	3	0,45	46	105	37
DELICATE 40°C	2,5	0,55	46	90	37
WOOL <sup>2)</sup> 30°C	1,5	0,35	50	65	32
<b>Standard cotton programmes</b>					
Standard 60°C cotton	7	0,95	47	255	60
Standard 60°C cotton	3,5	0,65	39	188	60
Standard 40°C cotton	3,5	0,59	39	187	60

<sup>1)</sup> At the end of spin phase.

<sup>2)</sup> Not available for some models.

Off Mode (W)	Left On Mode (W)
0.48	0.48
The information given in the chart above is compliant with the EU Commission regulation 1015/2010 implementing directive 2009/125/EC	

## OPTIONS

### TEMPERATURE

With this option you can change the default temperature.

Indicator  = cold water

The indicator of the set temperature comes on.

### SPIN

With this option you can set the spin speed. For the maximum spin speeds see "Programmes".

The indicator of the set speed comes on.



To drain the water refer to 'At the end of the programme'.

## RINSE HOLD

Select this option to reduce creasing:

- The washing programme ends with water in the drum. The drum turns regularly to reduce creasing.
- The door stays locked. You must drain the water to unlock the door.



To drain the water refer to "Draining water out after the end of the cycle".

## QUICK

With this option you can decrease the programme duration.

Use this option for items with light soil or items to refresh.

## SETTINGS

---

### Acoustic signals

The acoustic signals operate when:

- The programme is completed.
- The appliance has a malfunction.

To **deactivate/activate** the acoustic signals, touch the buttons

RINSE HOLD and QUICK at the same time for 4 seconds.

The related indicator comes on.

## EXTRA RINSE

With this option you can add some rinses to a washing programme.

Use this option for persons allergic to detergents and in areas where the water is soft.

The related indicator comes on.

## DELAY START

With this option you can delay the start of a programme from 30 minutes to 20 hours.

The related indicator comes on and the display shows the delay time.



If you deactivate the acoustic signals, they continue operate when the appliance has a malfunction.

## BEFORE FIRST USE

---

1. Put a small quantity of detergent in the compartment for washing phase.
2. Set and start a programme for cotton at the highest temperature without laundry.

This removes all possible dirt from the drum and the tub.

## DAILY USE

---



**WARNING!** Refer to Safety chapters.

### Loading the laundry

1. Open the appliance lid.

2. Push the button **A**.

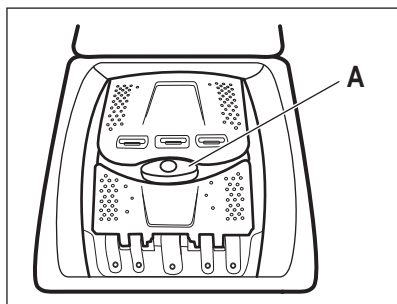

The drum opens automatically.

3. Put the laundry in the drum, one item at a time.
4. Shake the items before you put them in the appliance.

Make sure not to put too much laundry in the drum.

5. Close the drum and the lid.



**CAUTION!** Before you close the lid of your appliance, make sure that you close the drum correctly.

## Detergent compartments. Using detergent and additives

1. Measure out specified detergents for washing machine the detergent and the fabric conditioner.
2. Put the detergent and the fabric conditioner into the proper compartments.



Always obey the instructions that you find on the packaging of the detergent products.

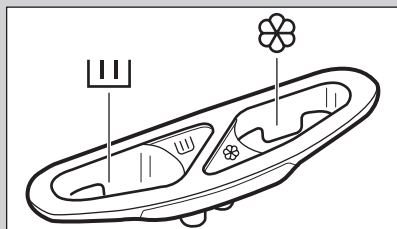

Detergent compartment for washing phase.



Compartment for liquid additives (fabric conditioner, starch).

The mark **M** is the maximum level for the quantity liquid additives.

## Setting a programme

1. Turn the programme knob to switch the appliance on and set the programme:
  - The indicator of the button START/PAUSE flashes.
  - The display shows the programme duration.
2. If necessary, change the spin speed or add available options. When you activate an option, the indicator of the set option comes on.



If you set something incorrect, the display shows the message **E r r**.

## Starting a programme without the delay start

Press the button START/PAUSE.

- The indicator of the button START/PAUSE stops to flash and stays on.
- The programme starts, the lid locks, the indicator DOOR LOCK is on.
- The programme time decreases with steps of one minute.



The drain pump can operate for a short time at the beginning of the washing cycle.

## Starting a programme with the delay start option

1. Press the button DELAY START again and again until the display shows the delay you want to set.
2. Press the button START/PAUSE:
  - The lid is locked and the indicator DOOR LOCK is on.
  - The appliance starts the countdown.
  - When the countdown is completed, the programme starts automatically.



You can cancel or change the set of the DELAY START option before you press the button START/PAUSE. After pressing the button START/PAUSE you can only cancel the DELAY START option.

To cancel the DELAY START option:

- a. Press the button START/PAUSE to set the appliance to pause. The indicator of button START/PAUSE flashes.
- b. Press the button DELAY START until the display shows . Press the button START/PAUSE again to start the programme immediately.

## Changing the options

You can change only some option before they operate.

1. Press the button START/PAUSE. The indicator flashes.
2. Change the options.
3. Press the button START/PAUSE. The programme continues.

## Opening the lid

While a programme operates or the delay start operates, the appliance lid is locked.



**CAUTION!** If the temperature and level of the water in the drum are too high, you cannot open the lid.

**Open the lid during the first 10 minutes of the cycle and when the delay start operates:**

1. Press the button START/PAUSE to pause the appliance.
2. Wait a couple of minutes and then you can open a lid.
3. Close the lid and press button START/PAUSE again. The programme (or the delay start) continues.

### Open the lid when the programme operates:

1. Turn the programme knob to position OFF to deactivate the appliance.
2. Wait for some minutes and then open the appliance lid.
3. Close the lid and set the programme again.

## Cancelling a running programme

1. Turn the programme knob to position OFF to cancel the programme and to deactivate the appliance.
2. Turn the programme knob again to activate the appliance. Now, you can set a new washing programme.



Before starting the new programme the appliance could drain the water. In this case, make sure that the detergent is still in the detergent compartment, if not fill the detergent again.

## At the end of the programme

- The appliance stops automatically. The acoustic signal operates (if it is activated).
- The indicator of the button START/PAUSE goes off and in the display  comes on.
- After a couple of minutes the door lock indicator DOOR LOCK goes off.
- You can open the lid.
- Remove the laundry from the appliance. Make sure that the drum is empty. Close the water tap.
- Turn the programme knob to position OFF to deactivate the appliance. Unplug the appliance.

- Keep the lid ajar, to prevent the mildew and odours.

**The washing programme is completed, but there is water in the drum:**

- The drum turns regularly to prevent the creases in the laundry.
- The indicator of button START/PAUSE flashes. The lid stays locked.
- You must drain the water to open the lid.

**To drain the water:**

1. Set a "Drain" or a "Spin" programme. If necessary, decrease the spin speed.
2. Press the button START/PAUSE. The appliance drains the water and spins.

## HINTS AND TIPS

---

### The laundry load

- Divide the laundry in: white, coloured, synthetics, delicates and wool.
- Obey the washing instructions that are on the laundry care labels.
- Do not wash white and coloured items together.
- Some coloured items can discolour with the first wash. We recommend that you wash them separately for the first times.
- Button up pillowcases, close zippers, hooks and poppers. Tie up belts.
- Empty the pockets and unfold the items.
- Turn multilayered fabrics, wool and items with painted illustrations inside out.
- Remove hard stains with a special detergent.
- Wash and pre-treat heavy soil stains before putting items in drum
- Be careful with the curtains. Remove the hooks and put the curtains in a washing bag or pillowcase.
- Do not wash laundry without hems or with cuts. Use a washing bag to wash small and/or delicate items (e.g. underwired bras, belts, tights, etc. ).
- A very small load can cause balance problems with the spin phase. If this

3. When the programme is completed, after a couple of minutes, you can open the lid.
4. Turn the programme knob to position OFF to deactivate the appliance.

### Stand by

Some minutes after the end of the washing programme, if you do not deactivate the appliance, the energy saving status activates. The energy saving status decreases the energy consumption when the appliance is on the standby.

Press one of the buttons to deactivate the energy saving status.

occurs, adjust manually the items in the tub and start the spin phase again.

### Stubborn stains

For some stains, water and detergent is not sufficient.

We recommend that you pre-treat these stains before you put the items in the appliance.

Special stain removers are available. Use the special stain remover that is applicable to the type of stain and fabric.

### Detergents and additives

- Only use detergents and additives specially made for washing machines:
  - powder detergents for all types of fabric,
  - powder detergents for delicate fabrics (40 °C max) and woollens,
  - liquid detergents, preferably for low temperature wash programmes (60 °C max) for all types of fabric, or special for woollens only.
- Do not mix different types of detergents.
- To help the environment, do not use more than the correct quantity of detergent.
- Obey the instructions that you find on the on packaging of these products.

- Use the correct products for the type and colour of the fabric, the programme temperature and the level of soil.
- If your appliance does not have the detergent dispenser with the flap device, add the liquid detergents with a dosing ball (supplied by the detergent's manufacturer).

## Ecological hints

- Always start a washing programme with the maximum load of laundry allowed.
- If necessary, use a stain remover when you set a programme with a low temperature.
- To use the correct quantity of detergent, check the water hardness of

your domestic system. Refer to "Water hardness".

## Water hardness

If the water hardness in your area is high or moderate, we recommend that you use a water softener for washing machines. In areas where the water hardness is soft it is not necessary to use a water softener.

To know the water hardness in your area, contact your local water authority.

Use the correct quantity of the water softener. Obey the instructions that you find on the packaging of the product.

## CARE AND CLEANING



**WARNING!** Refer to Safety chapters.

### External cleaning

Clean the appliance with soap and warm water only. Fully dry all the surfaces.



**CAUTION!** Do not use alcohol, solvents or chemical products.

### Descaling

If the water hardness in your area is high or moderate, we recommend that you use a water descaling product for washing machines.

Regularly examine the drum to prevent limescale and rust particles.

To remove rust particles use only special products for washing machines. Do this separately from the laundry wash.



Always obey the instructions that you find on the packaging of the product.

### Maintenance wash

With the low temperature programmes it is possible that some detergent stays in the drum. Perform a maintenance wash regularly. To do this:

- Remove all laundry from the drum.
- Select the cotton programme with the highest temperature with a small quantity of detergent.

### Lid seal

Regularly examine the seal. Clean it when needed, using ammonia cream cleanser agent without scratching the seal surface,



Always obey the instructions that you find on the packaging of the product.

## Cleaning the detergent dispenser

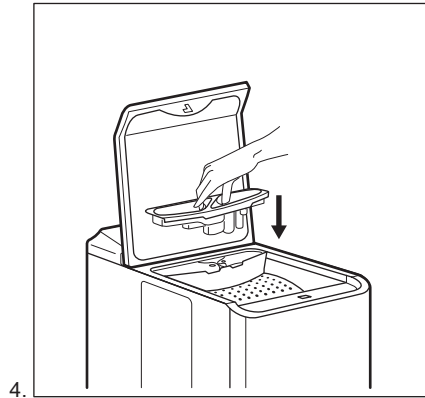
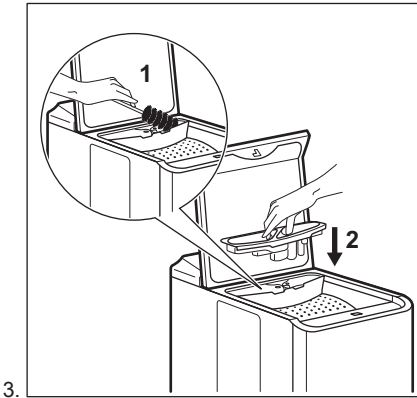
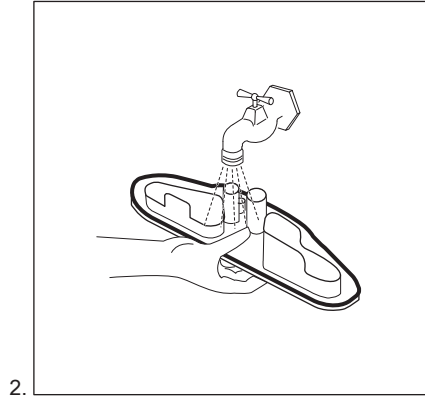
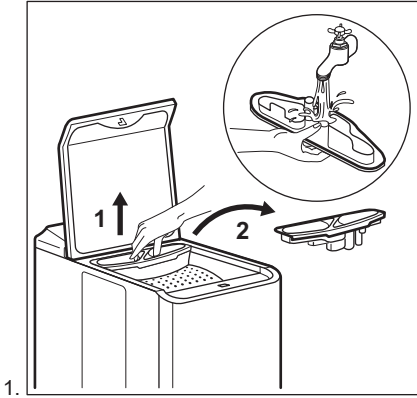

## Cleaning the inlet hose and the valve filter

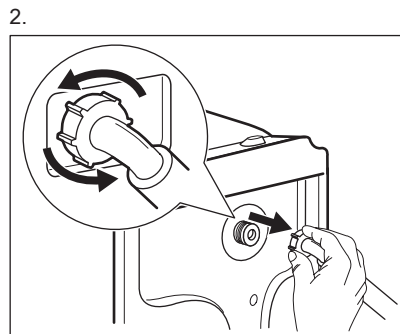
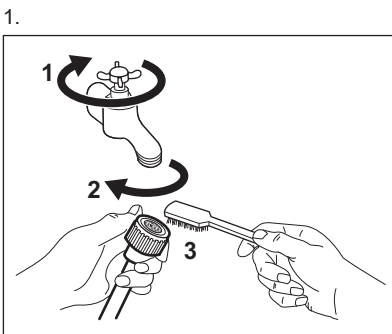

3.

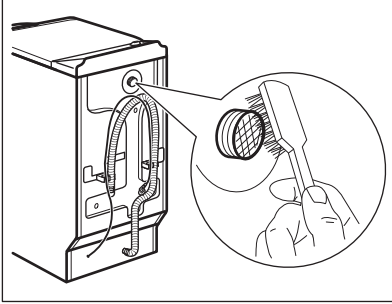

### Frost precautions

If the appliance is installed in an area where the temperature can be less than 0° C, remove the remaining water from the inlet hose and the drain pump.

1. Disconnect the mains plug from the mains socket.
2. Close the water tap.
3. Put the two ends of the inlet hose in a container and let the water flow out of the hose.

4.

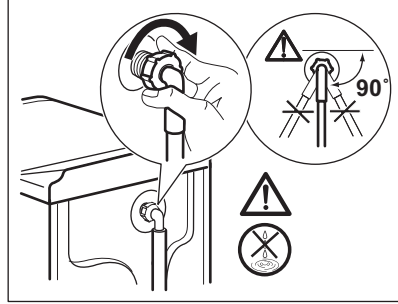

4. Empty the drain pump. Refer to the emergency drain procedure.
5. When the drain pump is empty, install the inlet hose again.



**WARNING!** Make sure that the temperature is higher than 0 °C before you use the appliance again.

The manufacturer is not responsible for damages caused by low temperatures.

## TROUBLESHOOTING



**WARNING!** Refer to Safety chapters.

### Introduction

The start of the appliance does not occur or it stops during operation.

First try to find a solution to the problem (refer to the table). If not, contact the Authorised Service Centre.

The **red** indicator of button flashes.



**WARNING!** Deactivate the appliance before you do the checks.



## Possible failures

Problem	Possible solution
The programme does not start.	<ul style="list-style-type: none"> <li>• Make sure that the mains plug is connected to the mains socket.</li> <li>• Make sure that the appliance lid and drum doors are closed properly.</li> <li>• Make sure that there is not a damaged fuse in the fuse box.</li> <li>• Make sure that the Start/Pause has been pressed.</li> <li>• If the delay start is set, cancel the setting or wait for the end of countdown.</li> <li>• Deactivate the Child Lock function if it is on (if available).</li> </ul>
The appliance does not fill with water properly.	<ul style="list-style-type: none"> <li>• Make sure that the water tap is open.</li> <li>• Make sure that the pressure of the water supply is not too low. For this information, contact your local water authority.</li> <li>• Make sure that the water tap is not clogged.</li> <li>• This problem may be caused by the filter of the inlet hose or the valve drain filter which may be clogged. Refer to "Care and cleaning". If problem remains please contact the Authorised Service Centre.</li> <li>• This problem may be caused by the filter of the inlet hose or the valve drain filter which may be kinks or bends. Refer to "Care and cleaning". If problem remains please contact the Authorised Service Centre.</li> </ul>
The appliance does not drain the water.	<ul style="list-style-type: none"> <li>• Make sure that the sink spigot is not clogged.</li> <li>• Make sure that the drain hose has no kinks or bends.</li> <li>• This problem may be caused by the clogged drain filter. Please contact the Authorised Service Centre.</li> <li>• Make sure that the drain hose is in the correct position. The hose may be too low.</li> <li>• Set the drain programme if you set a programme without drain phase.</li> <li>• Set the drain programme if you set an option which ends with water in the tub.</li> </ul>
The spin phase does not operate or the washing cycle lasts longer than usually.	<ul style="list-style-type: none"> <li>• Set the spin programme.</li> <li>• Make sure that the drain filter is not clogged. Clean the filter, if necessary. Refer to 'Care and cleaning'.</li> <li>• This problem may be caused by the clogged drain filter. Please contact the Authorised Service Centre.</li> <li>• Adjust manually the items in the tub and start the spin phase again. This problem may be caused by balance problems.</li> </ul>
There is water on the floor.	<ul style="list-style-type: none"> <li>• Make sure that the couplings of the water hoses are tight and there is not water leakages.</li> <li>• Make sure that the drain hose have no damages.</li> <li>• Make sure you use the correct detergent and the correct quantity of it.</li> </ul>

Problem	Possible solution
You cannot open the appliance lid.	<ul style="list-style-type: none"> <li>• Make sure that the washing programme is finished.</li> <li>• Set the drain or the spin programme if there is water in the drum.</li> </ul>
The appliance makes an unusual noise.	<ul style="list-style-type: none"> <li>• Make sure the levelling of the appliance is correct. Refer to 'Installation'.</li> <li>• Make sure that the packaging and/or the transit bolts are removed. Refer to 'Installation'.</li> <li>• Add more laundry in the drum. The load may be too small.</li> </ul>
The washing results are not satisfactory.	<ul style="list-style-type: none"> <li>• Increase the detergent quantity or use a different detergent.</li> <li>• Use special products to remove the stubborn stains before you wash the laundry.</li> <li>• Make sure that you set the correct temperature.</li> <li>• Decrease the laundry load.</li> </ul>
You cannot set an option.	<ul style="list-style-type: none"> <li>• Make sure that you press only the wanted button(s).</li> </ul>

After the check, activate the appliance. The programme continues from the point of interruption.

If the problem occurs again, contact the Authorised Service Centre.

If the display shows other alarm codes. Deactivate and activate the appliance. If the problem continues, contact the Service.

## TECHNICAL DATA

Dimension	Width/ Height/ Depth/ Total depth	400 mm/ 890 mm/ 600 mm/ 600 mm
Electrical connection	Voltage Overall power Fuse Frequency	220-230 V 2200 W 10 A 50 Hz
Level of protection against ingress of solid particles and moisture ensured by the protective cover, except where the low voltage equipment has no protection against moisture		IPX4
Water supply pressure	Minimum Maximum	0,5 bar (0,05 MPa) 8 bar (0,8 MPa)
Water supply <sup>1)</sup>		Cold water
Maximum Load	Cotton	7 kg
Energy Efficiency Class		A+++
Spin Speed	Maximum	1000 rpm

<sup>1)</sup> Connect the water inlet hose to a water tap with a 3/4" thread.

# INSTALLATION



**WARNING!** Refer to Safety chapters.

## Unpacking

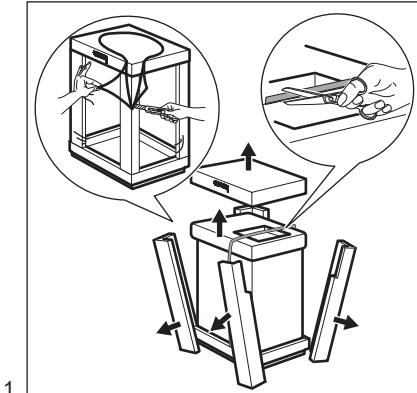

1.

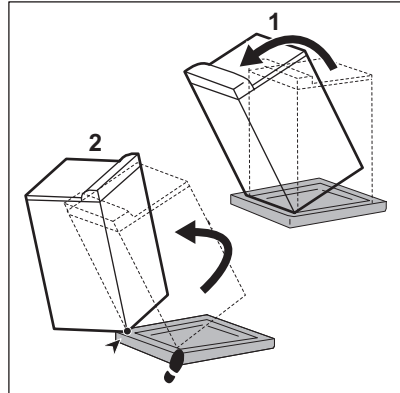

2.

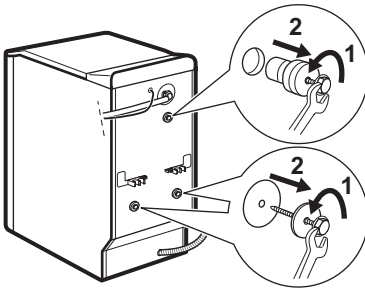
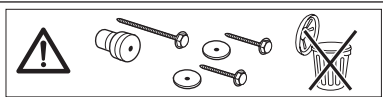

3.

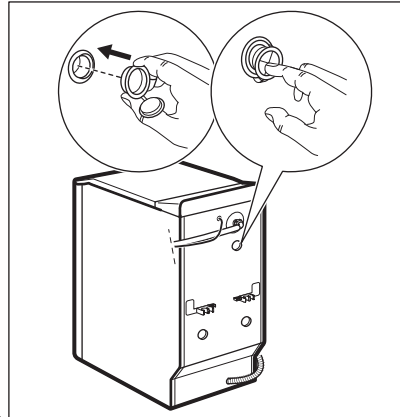

4.

### Positioning

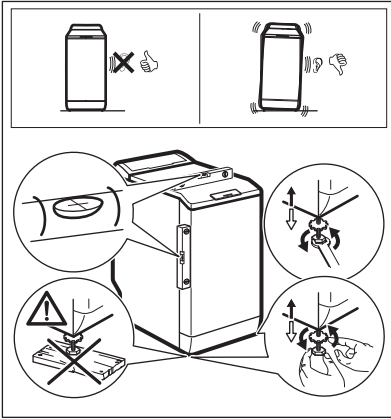

### Water supply

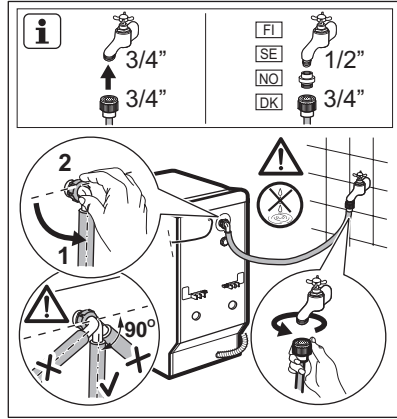

### Drainage

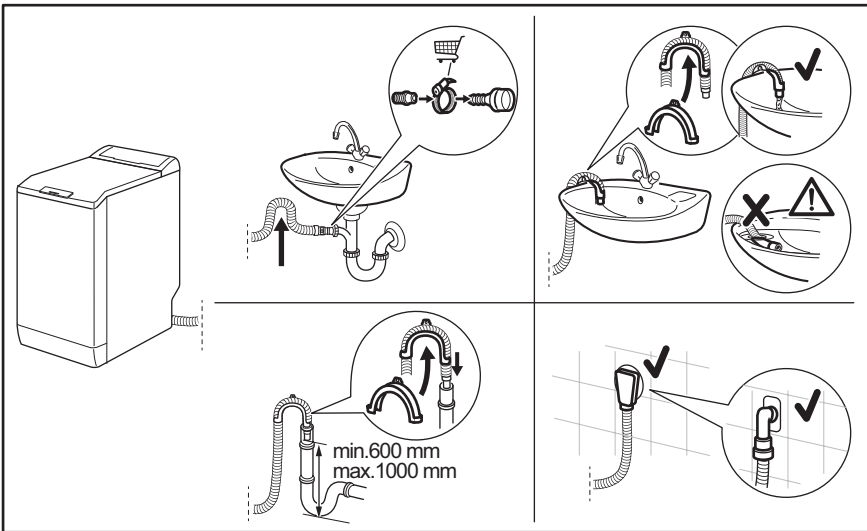

### ENVIRONMENTAL CONCERNS

Recycle materials with the symbol . Put the packaging in relevant containers to recycle it. Help protect the environment and human health by recycling waste of electrical and electronic appliances. Do

not dispose of appliances marked with the symbol with the household waste. Return the product to your local recycling facility or contact your municipal office.

EN Parts Name	Hazardous substances						
	Pb	Hg	Cd	Cr6+	PBBs	PBDEs	
Cabinet (including floater and back panel)	○	○	○	○	○	○	
Washing group (including drum, tub, heater, pulley)	X	○	○	○	○	○	
Motor (including belt)	X	○	○	○	○	○	
Hydraulics (inlet and drain hoses, pressure switch, pumps, including electrovalves)	X	○	○	○	○	○	
Control panel (including sensors, electronic boards - user interface, main board, motor control board)	X	○	○	○	○	○	
Door (including hinge)	X	○	○	○	○	○	
Wirings and power cord	X	○	○	○	○	○	
Worktop	○	○	○	○	○	○	

**Note:**

1. This table is compiled according to SJ/T11364-2014.
2. ○ means this kind of hazard substance content in all the homogenous material of this part is under the limitation regulated in GB/T 26572-2011.
3. X means this kind of hazard substance content in at least one homogenous material of this part is above the limitation regulated in GB/T 26572-2011.
4. For these parts with X in the above table, there is no replacement solution due to technique limitation in the industry; however, this may change with the technique improvement.
5. Under normal usage condition, the environment friendly usage period is 15 year.





