

gemini
ITALY

GDW24W

Dehumidifier User Manual

抽濕機使用說明書

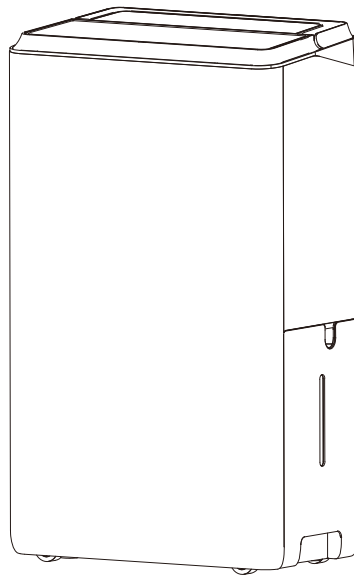

Please read this user manual carefully before using and retain it for reference.

使用本產品前請仔細閱讀，並妥善保管，以備查閱！

If have queries, please contact the service center for support.

如有疑問請與服務中心或經銷商聯繫。

- **Safety Instruction**

- Please be sure your electricity is correct (The voltage is matching with rating label).
- Do not place the machine near the appliance produced high temperature. Since the high temperature might damage the plastic and caused fire. Do not expose the machine under the sunshine, to avoid the damage of casing
- Do not operate and place the machine with lots of dust or corrosive gas or flammable or explosive gas, to avoid danger.
- Always guide if children operate. Never disassemble the unit, and never try to carry out repair or replace the unit's spare parts by yourself. Please coordinate with qualified personal to repair the machine.
- Place the machine in the flat and stable surface to prevent vibration and noise.
- Please unplug the power plug once the machine is dumped.
- Never cover the machine when it's running to prevent damage.
- Make sure the inlet and outlet ventilation are not blocked at all times.
- Do not spray water on the unit, spraying water may cause malfunctioning and electric shock.
- Never pull the socket by using damp hands.
- Always switch off before unplugging to avoid electric shock.
- If you do not use for a long time, shutdown and unplug the power plug, then pour out the water from the tank and wipe it clean.
- Do not pull out power wire by force because it will damage the power wire and cause damage.
- When the machine is operating, it is forbidden to insert hand or other small shaft in the air inlet or outlet, to prevent contact any parts inside or the rotating blower. It will damage the machine and cause danger.
- Pour out the water in the tank before moving the machine.
- In the low temperature and high humidity winter, please set the unit operating in dry clothes mode. (Under the dry clothes mode, the machine could operate continuously.)
- Note: When dry clothes, please do not hang the clothes above the outlet. To prevent the water drops into the machine from outlet and cause malfunction. When the machine is running, please make sure the minimum distance between the unit and the wall or other obstacles from all sides.

- Operation Environment

- Working temperature: 5°C-32°C · 30% RH ~ 90% RH
- This machine is suitable for indoors, e.g. Living room, office, bedroom.
- Make sure the door and window are closed before turning on the unit to get the best result.
- Ensure that the unit is placed on a stable and flat floor surface. If the floor's surface is not even, there is a risk that the unit may be unstable and topple over. Also, it will cause excessive vibration and noise.

- DESCRIPTION

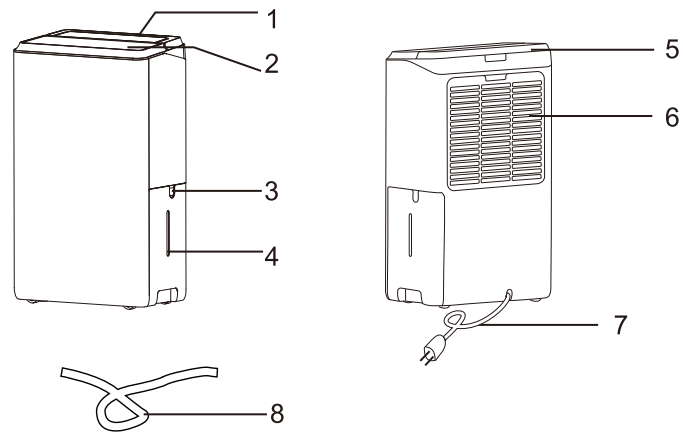

- Component Description

1. Control panel	5. Handle
2. Air outlet	6. Air intake grille
3. Bucket	7. Power cord
4. Water level view window	8. Drainpipe



Note: All the illustrations in this manual are for explanatory purposes only, your appliance may be slightly different.

- **Please remove the accessory from the bucket before use**

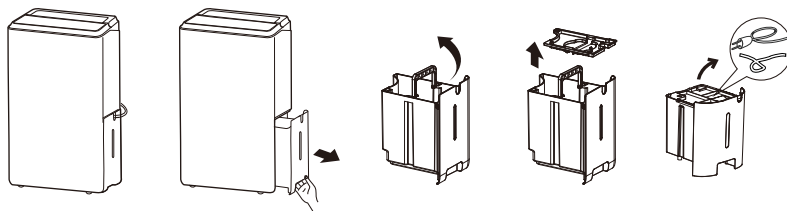
- Remove the bucket from appliance.
- Rotate handle to vertical position.
- Take out the cover of bucket.
- Take out of the plug, and other accessories.
- Correctly put back the cover into bucket.
- Correctly put back the bucket into the appliance.



- The accessories are included:

	Chip of bucket
	Drainpipe

- All the illustrations in this manual are for explanatory purposes only. your appliance may be slightly different.
- Be sure all accessories are removed from the packing and bucket before use.

Installation

Take out the power cord from bucket, remove the power cord and other accessories from it. Install the chip on the bucket.

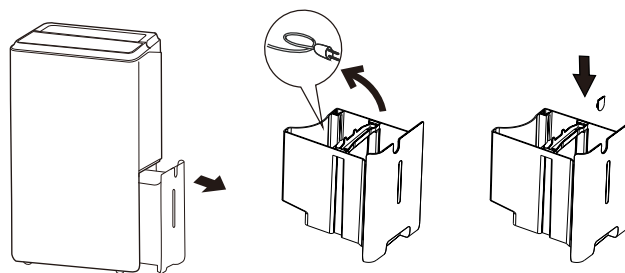

- Control Panel and Buttons

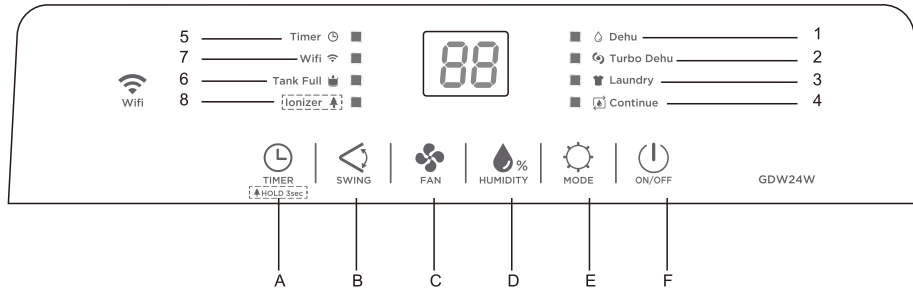

1 - Dehumidifying mode symbol	A - Timer button
2 - Turbo symbol	B - Swing button
3 - Laundry symbol	C - Fan speed button
4 - Continue symbol	D - Humidity button
5 - Timer symbol	E - Mode button
6 - Tank full symbol	F - On / Off button
7 - Wifi symbol	
8 - Ionizer symbol	

Note:

- When machine power connected, the display will flash "AP", it means machine include Wi-fi function. It will flash 5 times and turn in standby mode with symbol "--".
- For Wi-Fi connection, please see the Wi-Fi function user manual.

- "  " button

On / off power supply used to control the start-up or shut down the appliance.

- Humidity Selection:



Press "  " to select the indoor humidity level you expect to achieve, adjustable range is

40%-50%-60%-70% RH.

- Mode Selection:

Under power on status, press" Mode" button for choosing different modes.

- Dehumidifying mode

Press the "  " button until the " Dehu " symbol is lights. Press the "  " to choose the humidity desired.

The screen will display the setting humidity, and after few seconds, turn to display the ambient humidity.

- Press the "  " to choose the fan speed, High / Low.

- Turbo mode

Press the "  " button until the " Turbo Dehu " symbol is lights. The setting humidity is 30% RH, and the fan speed is high and cannot be adjusted.

- Laundry mode

Press the "  " button until the " Laundry " symbol is lights. The setting humidity is 15% RH, and the fan speed is high and cannot be adjusted.

After runs 24 hours, the appliance is quit laundry mode, turn to Dehumidifying mode and set humidity 60%RH, fan speed is Low.

- Continuous mode

Press the "  " button until the " Continue " symbol is lights. The setting humidity is 15%RH and

press the "  " to choose the fan speed, High / Low.

- Ionizer function

When the appliance is running, hold the "  " button 3 seconds until the "Ionizer" symbol is lights.

Hold the "  " button 3 seconds again to close the ionizer function.

- "  " button

Press the "  " button to swing up and down.



Press the "  " button again to stop swing.

- "  " button

This timer can be used to delay the appliance start-up or shutdown, this avoids wasting electricity by optimizing operating periods.

- Programming start up

Turn on the appliance, choose the mode you want, for example Dehumidify mode. Turn off the appliance.

- Press the "  " button, the " Timer " symbol starts to **flash**, press the "  " to adjust the set time from 1-24 hours. Each press for 1-hour adjustment. In 5 seconds without the operation, the timer start function. Press the "  " button again to cancel the Timer.

- Programming shut down

When the appliance is running, press the  button. the "  " symbol starts to **flash**, press the "

 " to adjust the set time from 1-24 hours. Each press for 1-hour adjustment. In 5 seconds

without the operation, the timer start function. Press the "  " button again to cancel the Timer.

- Alarm of bucket full

When bucket is full, "  " symbol is flashing. The compressor and fan will shut off, and 3 min later make a beeping noise, the unit will not run again until the bucket is emptied and properly placed back inside the unit.

The bucket should be cleaned every week to prevent the growth of mold, mildew and bacteria. Use a mild detergent to clean. Once clean, completely dry the bucket and place it back inside unit.

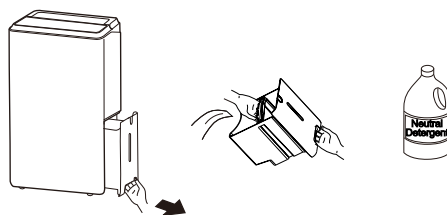

Note: Hold the bucket with both hands when emptying.

Note: When the bucket is full or removed from the unit, the compressor will turn off, but the fan will continue to run for a few minutes. This is completely normal. The unit will not be removing moisture from the air at this time.

Note: Do not place the bucket on the floor when it is full as it is uneven on the bottom and water may spill.

Note: During operation, it is normal for the unit to exhaust warm air from the top of the unit.

- Continuous drainage

Connect the drainpipe on the hole of unit, then the unit can continuously run without clean the bucket.

- 1) Put the unit on level floor, take out the bucket, remove the chip of bucket.
- 2) Install the pipe on drain nozzle.
- 3) Put back the bucket correctly and make the drainpipe on gap of bucket, don't press the pipe.
- 4) Press "  " button to run the unit.

Note: If no need the function of continuous drain, please remove the drainpipe and put back the bucket in unit correctly, then the water will flow into bucket.

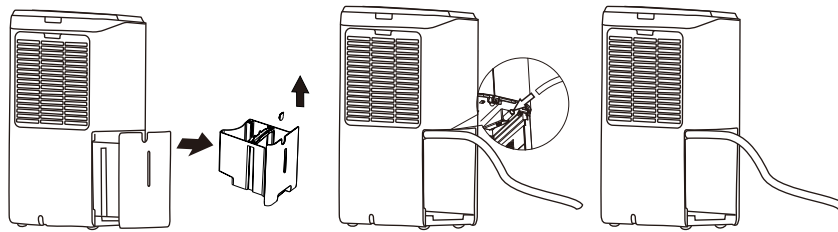

Note: Please install the drainpipe follow as shown picture.

Please install the drainpipe correctly, or the water cannot drain from the pipe.

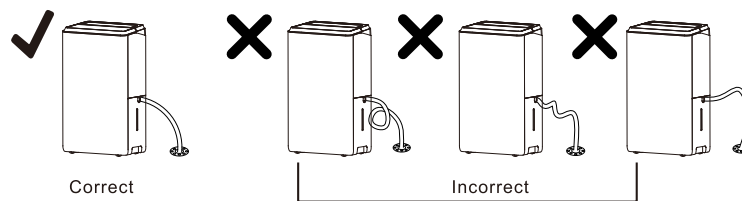

Notice:

If the unit put on the un-level ground or not correctly install the drainpipe, the water will splash out from the bucket and stop running.

If that happened, please check the ground is whether horizon, and the drainpipe is correctly installed.

At the same time, the bucket needs to be installed correctly.

AUTOMATIC DEFROST

When frost builds up on the evaporator coils, the compressor will cycle off and the fan will continue to run until the frost disappears. When the coils are completely defrosted, the compressor or fan will automatically restart and resume the dehumidifying.

Location requirements:

The unit operating in a basement will have little no effect in drying out an adjacent enclosed storage area, such as a closet, unless there is adequate circulation of air in and out of the area.

- Do not use at outdoors area.
- This appliance is intended for indoor use only. Place the appliance on a smooth, level floor surface that is strong enough to support the unit with a full bucket of water.
- Allow at least 45cm of around and above space away from the wall for efficient working.
- Place the appliance in an area where the temperature will not below 5°C
- Use the dehumidifier in cooking, laundry, bathing and dish - washing areas that have excessive moisture.
- Place the dehumidifier away from a clothes dryer.
- Use the dehumidifier in a basement to help prevent moisture damage.
- The dehumidifier must be operated in an enclosed area for more efficiency,
- Close all doors, windows and other outside openings to the room.
- Do not block the air inlet or outlet of the appliance.
- Reduced air flow will result in poor performance and could damage the unit.

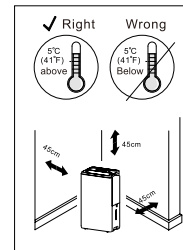

● CLEAN AND MAINTENANCE

Before cleaning or maintenance, turn the appliance off by pressing the "POWER" button on the control panel wait for a few minutes then unplug from the mains socket.

● CLEANING THE CABINET

You should clean the appliance with a slightly damp cloth then dry with a dry cloth.
Never wash the appliance with water, it could be dangerous.
Never use petrol, alcohol or solvents to clean the appliance.
Never spray insecticide liquids or similar.

● CLEANING THE FILTER

To keep your appliance working efficiently · you should clean the filter at least one a week.
The filter can take out as shown.

To avoid hurt, avoid contacting the metal parts of the appliance when removing or re-installing the filter.
It can result in the risk of personal injury.

Use a vacuum cleaner to remove dust from the filter. If it is very dirty, immerse in warm water and rinse number of times. The water should never be hotter than 40°C. After washing, leave the filter to dry then attach the intake grille to the appliance.

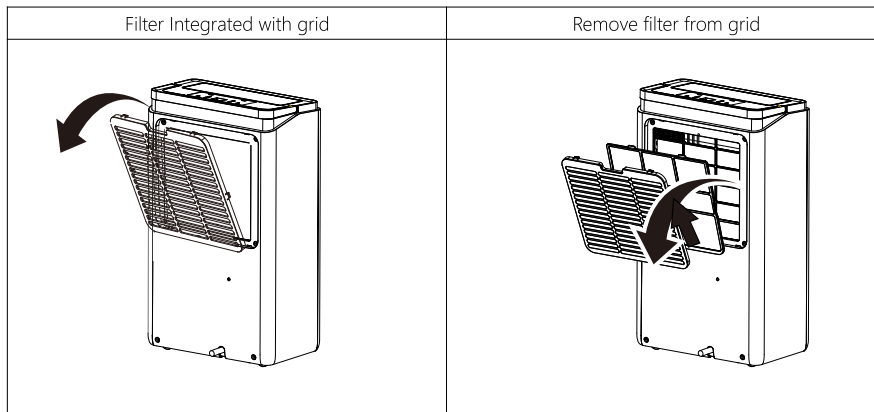



END OF SEASON OPERATIONS

- To unplug from the mains socket, empty the bucket, remove the cap.
- Pour out all water left inside the appliance. When all the water has been drained, put the cap back in place.
- Clean the filter and dry thoroughly before putting back.
- Cover the appliance prevent from dust.
- Store the appliance upright in a dry location.

START OF SEASON CHECKS

Make sure the power cable and plug are undamaged and the earth system is efficient. Follow the installation instructions precisely.

● TROUBLESHOOTING

Problem	Possible Causes	Solutions
Dehumidifier does not start	The dehumidifier is unplugged.	Make sure the dehumidifier's plug is pushed completely into the outlet.
	The fuse is blown/circuit breaker is tripped.	Check the house fuse/circuit breaker box and replace fuse or reset breaker.
	Dehumidifier has reached its present level or the bucket is full.	The dehumidifier automatically turns off when either condition occurs. Change to a lower setting or empty the water bucket and replace properly.
	Bucket is not in the proper position.	The bucket must be in place and securely seated for the dehumidifier to operate.
	Power Failure.	There is a protective time delay (up to 3 min.) to prevent trip — ping of the compressor overload. For this reason, the unit may not start normal dehumidify for 3 min after it is powered back on.
Dehumidifier does not dry the air as it should	Not enough time allowed for unit to remove moisture.	When first installed · allow at least 24 hours to maintain the desired dryness.
	Airflow is restricted.	Make sure there are no curtains, blinds, or furniture blocking the front or back of the dehumidifier. See the CHOOSING A LOCATION section.
	Dirty filter.	See the CLEAN FILTER section.
	The Humidity Control may not be set low enough.	For drier air, press the  button to lower the percent humidity desired in the room · or set the dehumidifier to  for maximum dehumidify.
	Doors and windows may not be closed tightly.	Check that all doors, windows, and other openings are securely closed.
	Clothes dryer may be blowing moist air into the room.	Install the dehumidifier away from the dryer. The dryer should be vented outside.
	Room temperature is too low.	Moisture removal is best at higher room temperatures. Lower room temperatures will reduce the moisture removal rate. This model is designed to operate at temperatures above 5°C(41°F).
Appliance runs too long	The area is too large	The capacity of the appliance cannot meet the area of the room
	Doors and windows are open	Close the door and window

Frost appears on heat-exchanger	Appliance run recently or the room temperature is too low	It is normal, frost usually disappear in 60 min
Fan noise	The air is passing through the appliance	This is normal
Water on the floor	The drain connection may be aging or loose	Check the drain connection and the appliance is placed level
	The drainpipe is connected, but the water is not drained.	If use the bucket, remove the drainpipe and put back the drain cover; or install the drainpipe correctly

If the following error code appears, contact the after-sales service department for inspection and repair.

CODE	DESCRIPTION
EH	Humidity sensor failure
E1	Temperature sensor failure
E2	



WIFI Function User Manual



**Please read this user manual carefully before using and retain it for reference.
If have queries, please contact the service center for support.**

WI-FI APP INSTRUCTION MANUAL

Please scan the QR code to download the latest App software.

The latest App software integrated air conditioner, dehumidifier and Portable air conditioner



iOS



Android



SERVICE CONDITION

Thank you for choosing our air conditioner.

This manual apply to the air conditioners which has WiFi function.

Please read the manual carefully before using the product and keep it properly for further review.

Please do not unplug the WIFI module by yourself.

For technical update, there may be deviation of the actual items from the manual. We express our apologies.

Please refer to your actual product.

INSTALL THE APP

When download the APP software, you can install it in your smart phone.

After installation, you can find the "Smart Life" icon on your phone desk.

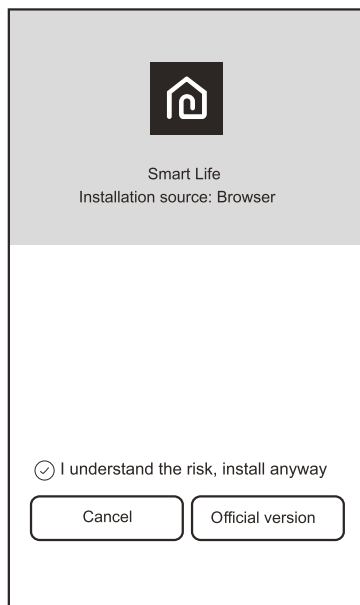

ACTIVATE QR CODE

1. When you first time enter the App, it will display activation interface, you can select scan activation QR code (click "Scan" button and scan the activation QR code in below page) or input "activation code" words (in be- low page), click "activate" button to active it.

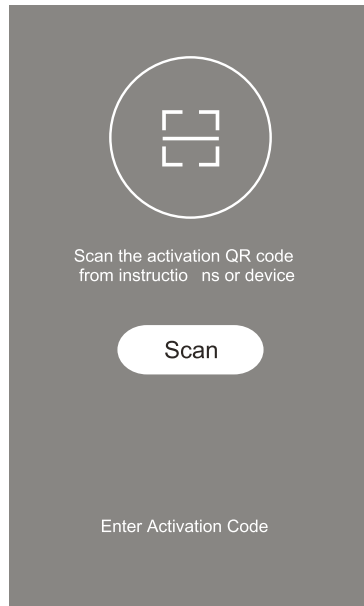

2. Dehumidifier activation QR code



3. Dehumidifier activation code WORDS: gemini

REGISTER USER ACCOUNT

When you first time use the App, you need to register an account. Click "Register" button to enter to the register interface. You can register with email or "Register with Mobile number".

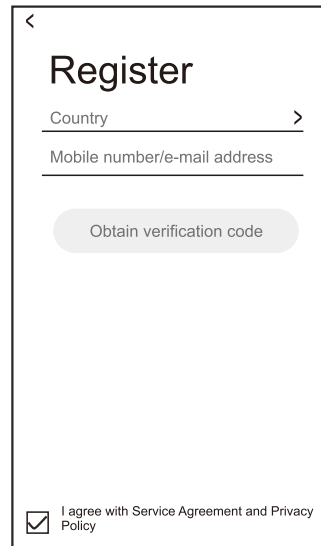

LOGIN USER ACCOUNT

1. Register account login, fulfill the registered email or phone number account and password, press "Login" button.
2. Phone number login, press "Sign in with SMS" button to enter the next page, fulfill the phone number and press "get" button to receive the confirm code, and fill in, then press "Login" button.

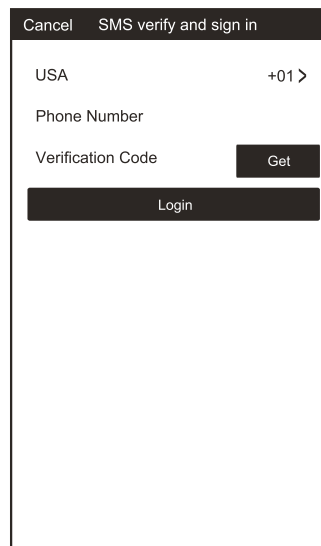
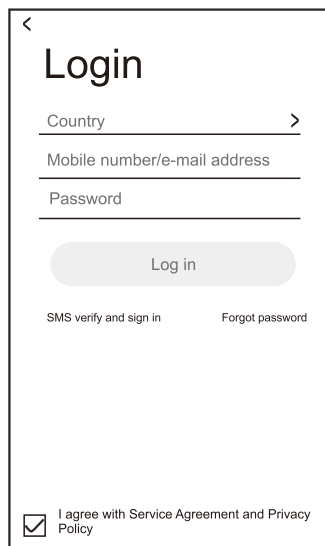

FORGET PASSWORD

1. Press the "Forgot password" button to the next page.
2. Fulfill the registered phone number or email account, press "Next" button to the next page.
3. You will receive the verification code, fulfill it, and set the new password, press "confirm" button.

The first screenshot shows the 'Login' screen with fields for Country, Mobile number/e-mail address, and Password. A 'Log in' button is at the bottom, along with links for 'SMS verify and sign in' and 'Forgot password'. A checkbox for 'I agree with Service Agreement and Privacy Policy' is at the bottom left.

The second screenshot shows the 'Request password' screen where the user enters their country (USA) and mobile number/E-mail, followed by a 'Next' button.

The third screenshot shows the 'Request password' screen where the user receives a verification code (+01 XXXXXXXXXX) and is prompted to 'Enter new password' and 'Confirm'.

ADD THE DEVICE

1. Press "Add Device" button to next page, select the product type.
2. There are two methods to do the device match, "CF" or "AP mode" You can choose by the different button

The first screenshot shows the 'Smart Life' home screen with a 'Welcome home' message and an 'Add Device' button at the bottom.

The second screenshot shows the 'Add Device' screen with two options: 'Add Manually' and 'Search Device'. Under 'Add Manually', there are icons for 'Large Home Ap...', 'Security & Sensors', 'Window Type Air Co...', 'Portable Air Conditioner', 'Split Air conditioner', and 'Fresh air purifier'.

The third screenshot shows the 'Add Device' screen in 'AP Mode' with a large 'CF' icon and a 'Next Step' button.

ADD THE DEVICE (CF MODE)

1. The system defaults to CF mode at first, Press "Next Step" to continue.
2. Select the home router, and fulfill the password of router, press "Next" to continue.
3. In standby, press the "FAN" key (or "TIMER" key, please refer to the prompts on the Add Device interface) on the control panel 6 times within 4 seconds until the LED screen show "CF" or "AP", which can make WIFI reset, there will be switch between "CF" and "AP" if press many times.

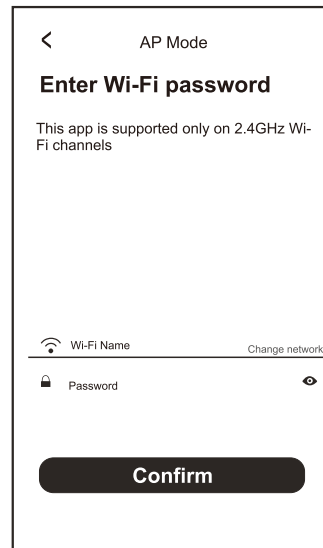
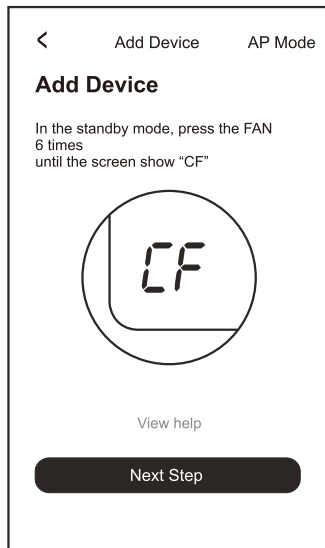

4. The APP software will automatically do the device match.
5. After match successfully, the page will display the prompt as below.
6. You can "Rename" the device name as you like, or share with family, or press "Done" to start to control the device

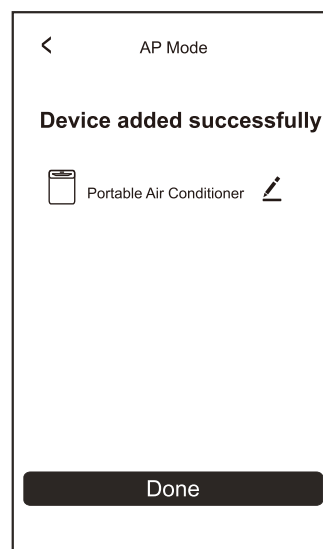
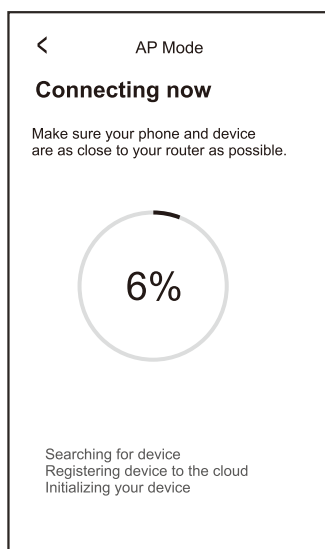

ADD THE DEVICE (AP MODE)

1. Click the "AP Mode" to the "AP" page. Press "Next Step" to continue.
2. Select the home router, fulfill the password, press "Next" to continue
3. In standby, press the "FAN" key (or "TIMER" key, please refer to the prompts on the Add Device interface) on the control panel 6 times within 4 seconds until the LED screen show "CF" or "AP", which can make WIFI reset, there will be switch between "CF" and "AP" if press many times.

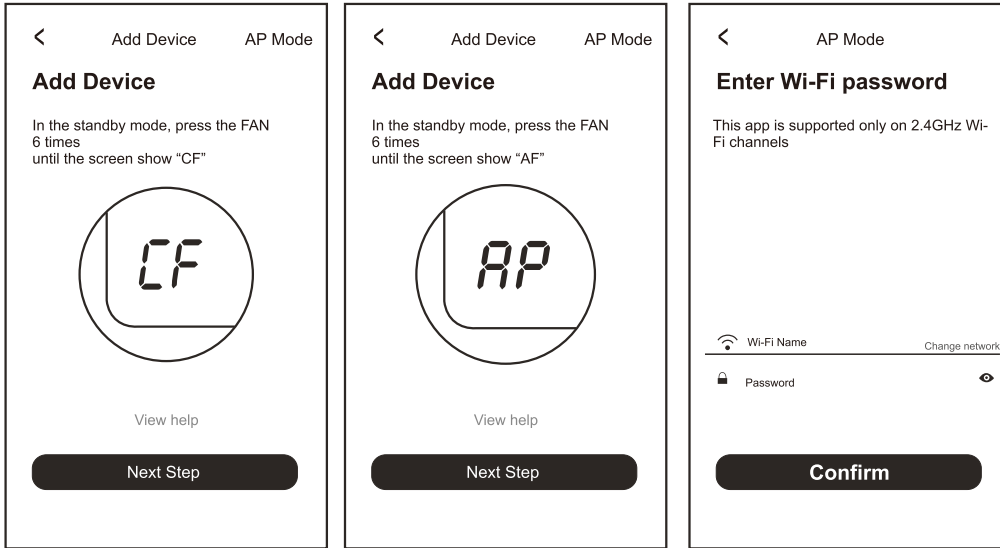

4. Select the AC Device as name "SmartLife-XXX" at the WLAN setting, then back to the APP interface. The APP will automatically do match

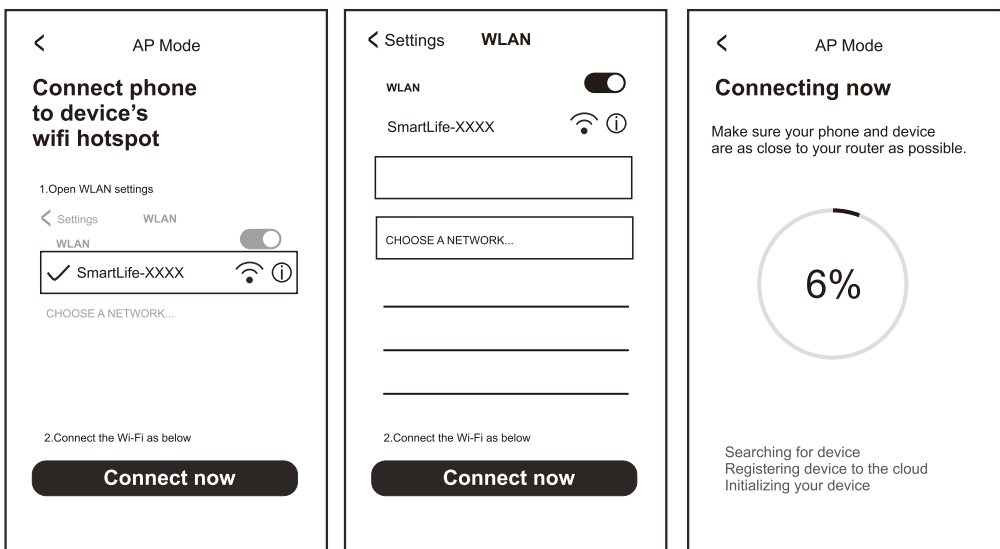

5. After match successfully, the page will display the prompt as below.

6. If match failed, the APP will mention it, and press "Retry" to try again.

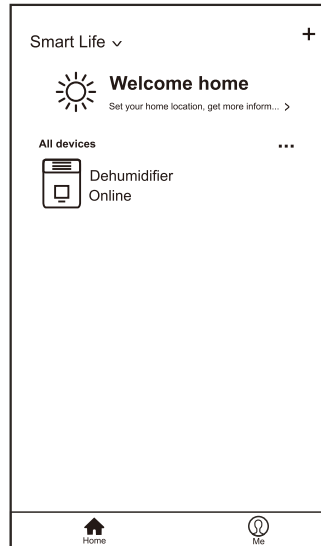
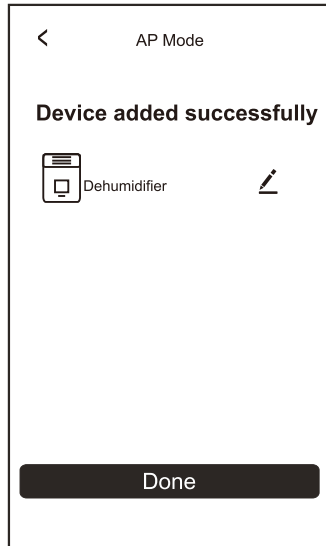

DEHUMIDIFIER CONTROL

1. Click the dehumidifier name to enter the control interface, turn ON/OFF, adjust the setting humidity.

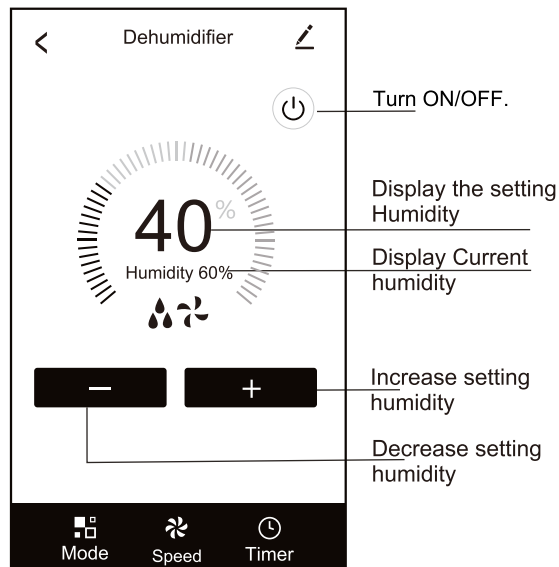

*For App update, there maybe deviation of the actual items from what is on the manual without prior notice. We express our apologies.

2. If **EH** appears, means Humidity sensor failure, please contact the after-sales service department for inspection and repair.

ERROR CODE

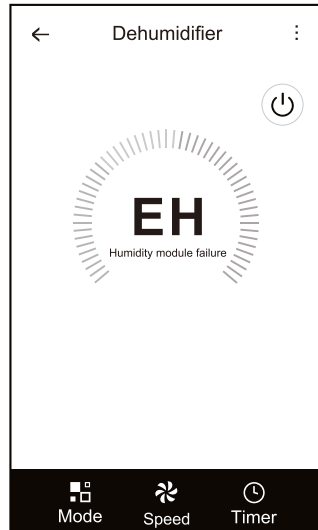

3. If **E1** appears, means temperature sensor failure, please contact the after-sales service department for inspection and repair.

ERROR CODE

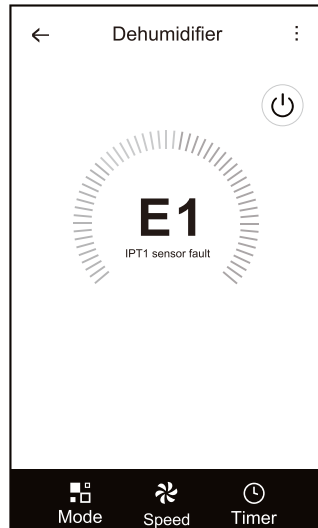

4. If the “” appears, means the tank water is full ,please empty the tank.

ERROR CODE

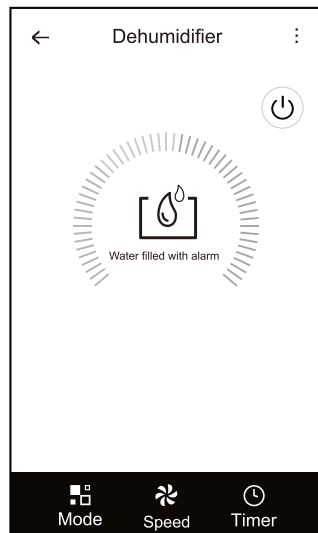

5. Setting Timer function. Click the "Timer" button, the APP will enter to timer setting interface. It will display the task scheduler set before. You can longterm press to edit or build a new scheduler by "Add Timer" button.

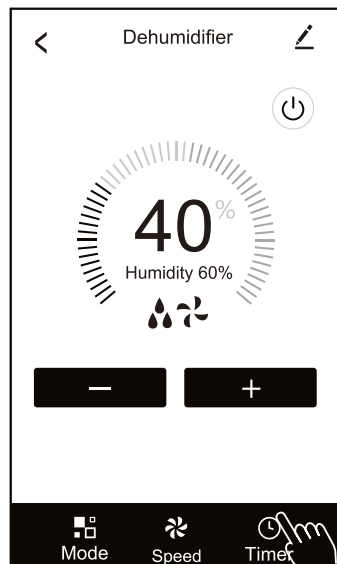

6. Click "ON" or "OFF" button to set Timer ON or Timer OFF.

You can set Hour, Minute, operate Mode, operate Fan Speed, humidity setting also the weekly Timer. After finish the setting, click the button to cancel or confirm.

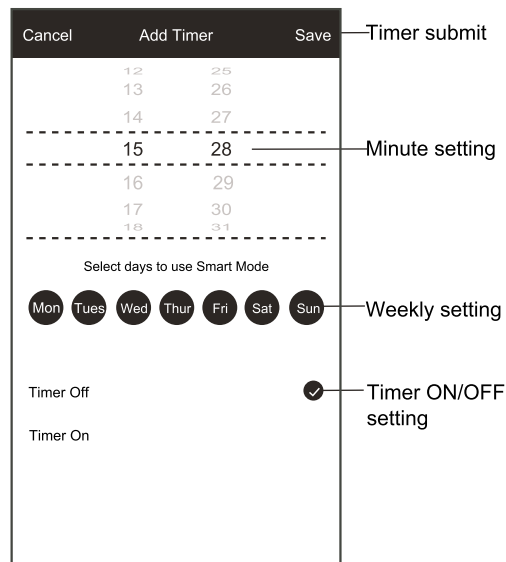

7. More setting. From the right-up corner, you can do more function setting, as Modify Device Name, Device Sharing, Device information, Feedback, Check for firmware update, Remove Device, Restore Manufacture setting.

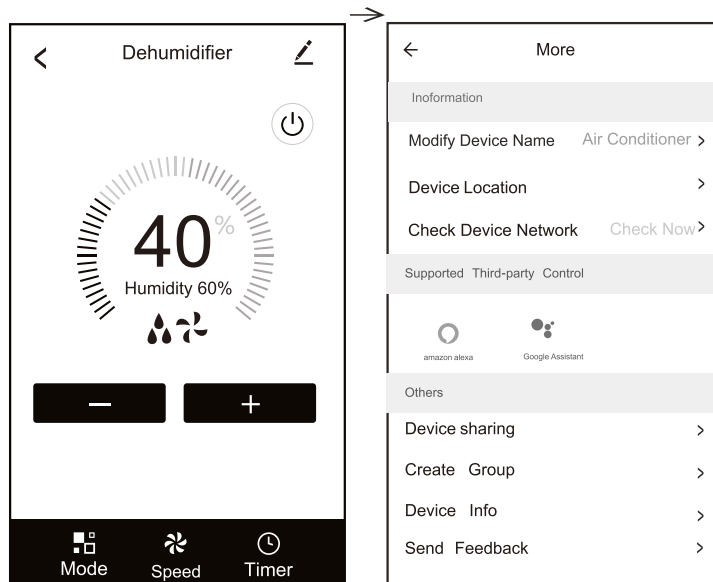

8. Profile. You can manage your personal information. It includes:
- a, Account information.
 - b, Scan QR code: Developers could preview the control interface.
 - c, Share Device: Display user s device sharing information.
 - d, Message Centre: Displays all messages that system sent to users.
 - e, Feedback: Where users could submit feedback online.
 - f, About: Displays the current App version information.

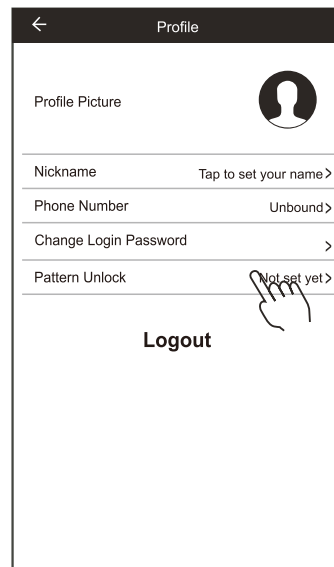
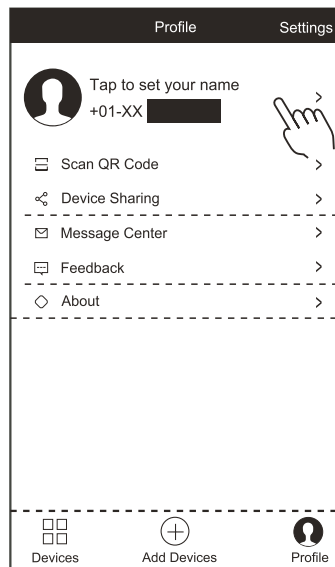

9. Pattern unlock. Tap "Pattern unlock" to set up your App unlock pattern.
After it is enabled, you need to draw the pattern to unlock the App.

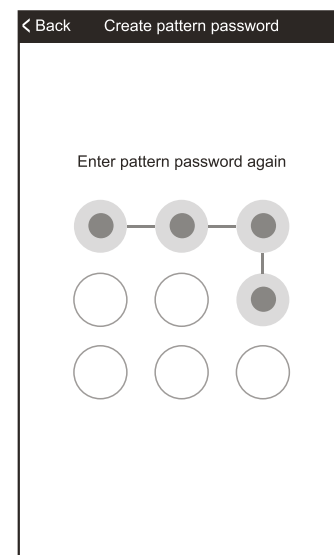
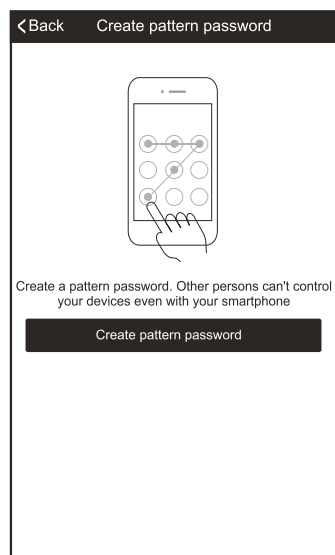

TROUBLE SHOOTING

Description	Analysis of cause
Appliance can't be configured successfully	<ol style="list-style-type: none"> 1. Check the mobile connected WIFI address and password is correct; 2. Check the appliance under configuration status; 3. There are any firewall or other restrictions have been set or not; 4. check the router work normally; 5. Make sure appliance, router and mobile work within signal scope 6. Check router shielding App or not
Mobile can't control appliance	<p>Software display: Identification failed, It means the appliance has been reset, and the mobile phone lost control permission. You need to connect WIFI to get permission again. Please connect the local network and refresh it. After all still can't work, please delete appliance and wait its refresh.</p>
Mobile can't find appliance	<p>Software display: Appliance out of line. Please check network working</p> <ol style="list-style-type: none"> 1. The appliance has been reconfiguration 2. Appliance out of power; 3. Router out of power; 4. Appliance can't connect to router; 5. Appliance can't connect to network through the router(under remote control mode); 6. Mobbile can't connect to router(under local control mode); 7. The mobile phone can't connect to network (under local control mode);

- **安全注意事項**

- 使用本機前，請先核對供電電壓和銘牌確認相符後方可使用！
- 不要將抽濕機放置在能產生強大熱力的電器附近，因為強大熱力可能損壞塑膠，及引起火災；也不要陽光下曝曬，以免損壞外殼
- 不要在塵埃較大或有腐蝕性氣體，易燃易爆氣體的場所使用，以免發生危險。
- 如與兒童一起使用，請給予適當的指導。請不要試圖拆卸，修改本機的配件。如有損壞，請由合資格的專業維修人員修理。
- 把抽濕機放置在一個穩固，平坦的地面上使用，以防止產生震動和噪音。
- 一旦抽濕機傾倒，請立即拔掉電源插頭。
- 抽濕機運行時，不可覆蓋機體，以免抽濕機發生故障。
- 不要阻擋進風口或出風口的空氣流動，以防止影響抽濕機性能或產生故障。
- 不要直接噴水到機體上清洗，以免引起抽濕機故障和觸電。
- 只可以在乾爽情況下，才可以插拔電源，否則可能引起觸電。
- 拔電源線插頭前要先關機，以免出現觸電或其他危險。
- 若長時間不使用，請關機及拔掉電源線插頭，然後倒掉水箱裡的水並擦拭乾淨。
- 不要拉扯電線拔出插頭，以免損壞電源線及造成事故。
- 抽濕機運行時，禁止用手及細小桿狀物體插入進風口或出風口內，以防止碰到裡面帶電部件和轉動的輪葉，損壞抽濕機造成事故。
- 移動抽濕機時，先將水箱中的水倒掉，以免濺出。
- 在低溫高濕的冬季，將抽濕機運行模式設定為乾衣模式（乾衣模式不受相對濕度控制，可連續運行）
注：在乾燥衣物的時候請不要將衣物懸掛於出風口正上方，防止滴水從出風口滴進機內，以避免發生故障。

● 使用環境

- 工作環境溫度 5°C-32°C · 30% RH ~ 90% RH
- 本機適合於客廳、書房、辦公室、倉庫、地下室以及地下車庫等室內環境使用。
- 使用本機時，請確保所有門窗都已關閉，以達到最高效率。
- 將抽濕機放置在穩固平坦的地面上使用，以免導致過大的震動而產生噪音。
- 機體不可傾斜放置，以免抽濕水溢出或抽濕機傾倒。

● 描述

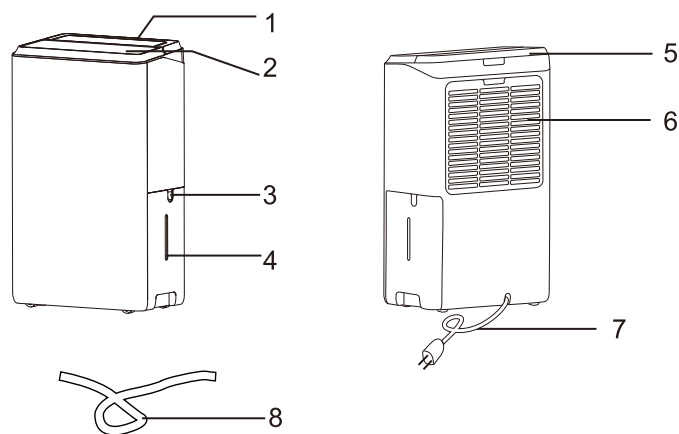

● 組件描述

1. 控制台	5. 提手
2. 出風口	6. 進風格柵
3. 水箱	7. 電源線
4. 水位觀察窗	8. 排水管

注: 本說明書中的所有圖示，均為示意圖，可能與實際略有不同，但不影響使用。

● 使用前請先從水箱中取出附件

- 取出水箱。
- 將提手旋轉至豎直狀態。
- 取出水箱蓋
- 取出水箱裡的電源線插頭以及附件。
- 將水箱蓋放回水箱中。
- 水箱正確放置回機器內。

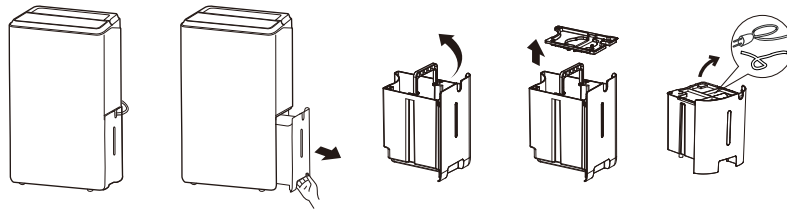

● 附件：

	水箱蓋片
	排水管

- 本說明書中的所有圖示均為示意圖，可能與實物略有不同，但不影響使用。
- 在使用前請確保所有的附件從包裝或水箱中取出。

安裝

首先從水箱中取出電源線先取出水箱，取出電源線和其它附件。將水箱蓋片裝回水箱上。

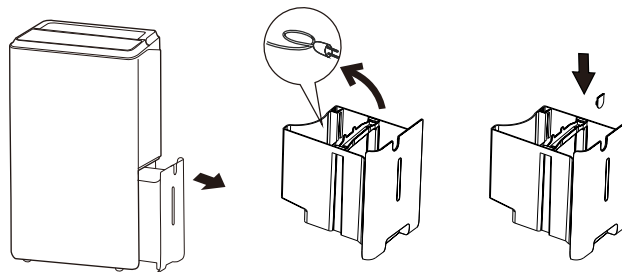

● 按鍵和顯示面板

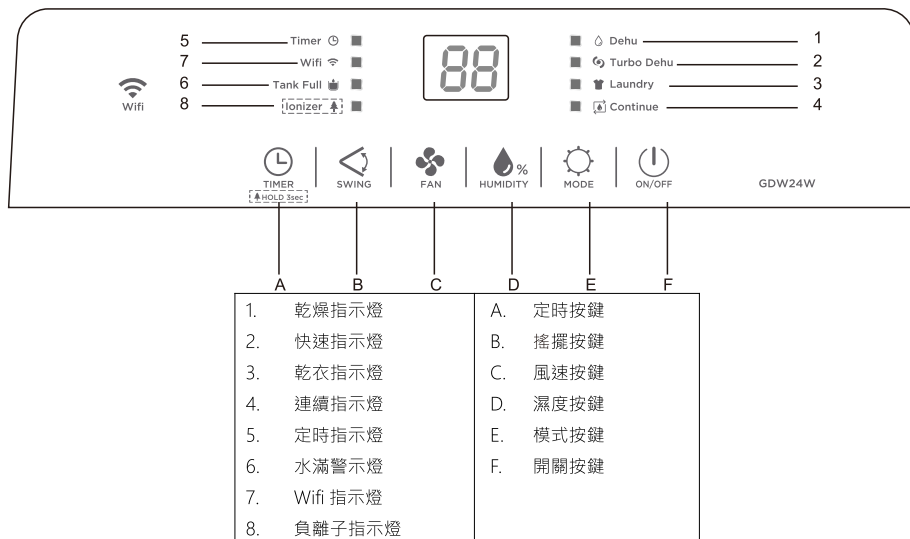

注：

- 機器在通電後，顯示幕上有“AP”閃爍，表示機器內置 WIFI 功能，閃爍約 5 次後，轉為顯示待機符號“--”。此後如果機器 WIFI 連接到網路後，“WIFI”指示燈會亮起，如果沒有連接到網格，“WIFI”指示燈熄滅。
- WIFI 連接方法，具體請參看 WIFI 連接說明書。

● “ON/OFF” 開/關按鍵

開/關按鍵，用來啟動或關閉機器。

● 濕度按鍵

按 “HUMIDITY” 選擇你期待達到的室內濕度水準，調節範圍為 40%-50%-60%-70%RH。

● 模式選擇:

在開機的情況下，按下“模式”模式按鍵，可以選擇不同的模式。

● 乾燥模式:

按 “MODE” 按鍵，直到 “Dehu” 指示燈亮，此時可以通過 “HUMIDITY” 調節期待的濕度水準，

顯示幕上會顯示設定濕度約 3 秒後，顯示當前環境濕度。

- 按 “  ” 可以選擇風速，高 / 低。

- 快速模式

按 “  ” 按鍵，直到 “ Turbo Dehu ” 指示燈亮，此模式下設定濕度為 30%RH，風速為高風，並且不可調節。

- 乾衣模式

按 “  ” 按鍵，直到 “ Laundry ” 指示燈亮，此模式下設定濕度為 15%RH，風速為高風，並且不可調節。

乾衣模式連續運行 24 小時後，會退出乾衣模式，轉為乾燥模式，設定濕度為 60%，風速低檔。

- 連續除濕模式:

按 “  ” 按鍵，直到 “ Continue ” 指示燈亮，此時機器會連續運行。

此模式下設定濕度為 15%RH，按 “  ” 可以選擇風速，高 / 低。

- 負離子功能:

按 “定時” 鍵三秒，直到 “Ionizer” 指示燈亮。

此時機器通過負離子發生器，向室內提供負離子，改善室內空氣品質，創造一個宜人的生活環境。



再按 “定時” 鍵三秒，可以關閉負離子功能。

- 搖擺功能

在機器運行的情況下，按下 “  ” 搖擺鍵，出風口會自動上下緩慢搖擺送風；



當停止不需要搖擺時，再次按下搖擺鍵，即停止擺動。

- 定時開機:

在待機的情況下，按下 “  ” 定時鍵進入設置定時開機模式，“定時” 指示燈開始閃爍，通過按 “  ” 鍵來

調整設定時間(1-24 小時)，每按一次鍵調整幅度為 1 小時。在 5 秒鐘內未進行操作，定時開機功能啟動，此時顯示幕定時指示燈亮起。再按一次為取消定時。

- **定時關機:**

在開機的情況下，按下 “” 定時鍵進入設置定時關機模式，“定時” 指示燈開始閃爍，通過按 “% ” 鍵來調整設定時間，每按一次鍵調整幅度為 1 小時。在 5 秒鐘內未進行操作，定時關機功能啟動，此時顯示幕定時指示燈亮起。再按一次為取消定時。

- **水滿保護功能:**

當水箱充滿水的時候，壓縮機和風機立即停止運行，“” 指示燈開始閃爍，三分鐘後發出報警聲，六分鐘後提示第二次，此後不再提示。此時把水箱的水清空並將水箱重新安裝到機內，5 秒鐘後“水滿” 指示燈停止閃爍，機器恢復工作。
為了防止產生灰塵和細菌需要把水箱每週都要清洗一次，用中性洗滌劑清洗水箱並將其乾燥後安裝回抽濕機內。

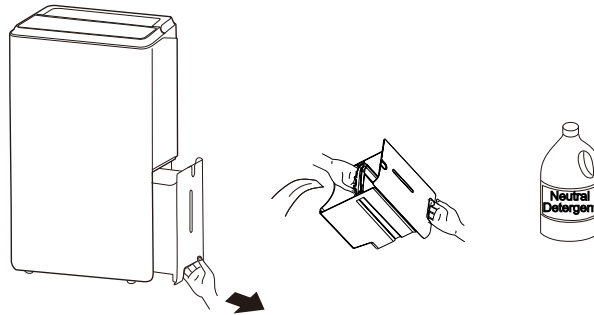

注意：請用雙手取出水箱，把水箱內的水清空，再裝回機器內。
注意：當降低空氣中濕度時，抽濕機會從前面把熱空氣排出。
注意：當水箱中有水時，請不要將水箱放在地板上，因為水箱底部不平，會導致水灑在地板上。
注意：當機器運行時，會有熱風從機器前方排出，這是正常的。

- **連續排水功能:**

把排水管連接到抽濕機的排水孔上，這樣會讓機器不用在清空水箱的情況下持續運行。
把抽濕機放在平穩的地板上，取出水箱，並取下水箱蓋片；
將排水管安裝在機器排水口；
將水箱安裝回正確位置，並將水管置於水箱缺口上，不要壓迫水管；
按 “” 啟動機器。
注意：如果不需要連續排水功能，請移除排水管，同時將水箱安裝回正確位置。

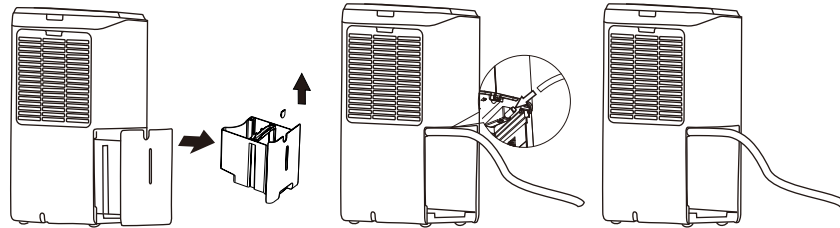

注意: 請按以下圖示安裝排水管。

- 排水管的放置如下圖所示。請正確放置排水管，否則可能無法將水排出。

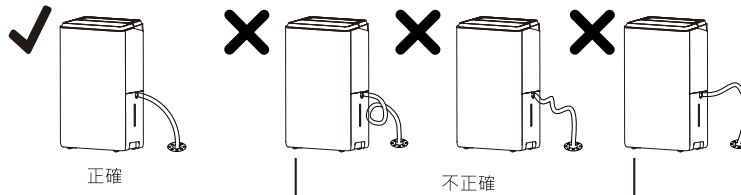

重要提示:

當把抽濕機放在不平的地面上或者沒有正確安裝排水管，會導致水灌滿水箱並讓機器停止運行。

如果這個情況發生，請檢查抽濕機的放置位置和排水管是否正確安裝。為了讓機器正常的運轉，水箱一定要正確放置。

- **自動除霜功能:**

當環境溫度太低時，會有霜出現在換熱器上，此時壓縮機會停止，但風扇會持續運轉，直到霜消失。

霜消失後，壓縮機會自動啟動，重新開始除濕。

- **位置要求:**

- 抽濕機禁止在狹小密閉的空間中使用，比如衣櫥裡。如果在這種狹小的空間中使用，請將衣櫥的門打開一定角度，使內外空氣流通。
- 不能在室外使用；抽濕機只限於在室內使用。請把抽濕機在光滑的地板表面、平整且足夠支撐滿滿一桶水地方。
- 讓各方向至少有 45cm 空間讓空氣流通。
- 請把抽濕機放置的地方溫度不會低於 5°C。
- 在廚房、洗衣區、沐浴房、洗碗區裡使用抽濕機時會產生更多的水分。
- 注意:請讓抽濕機遠離衣物烘乾機。
- 使用抽濕機可以防止潮濕損壞書籍或其它貴重物品。
- 在地下室使用的抽濕機有助於防止潮濕損壞物品。
- 抽濕機在一個封閉的區域使用，效果更明顯更有效。
- 不要堵塞機器進、出風格柵口，保持其通風順暢；否則可能減少機器的性能並且對機器有損害。

- **維護**

在每次進行清潔或者維修之前，請把電源插頭拔出，出於安全原因的考慮，切勿使用花灑頭/噴頭來清洗機器。

- **清潔外殼**

先使用濕布清潔，再用乾布擦乾；
切不可使用汽油、酒精或者溶劑來清潔機器；
切不可向機器噴射殺蟲劑或類似物品；

- **清潔過濾網**

如果過濾網變髒，這將影響空氣的迴圈以及除濕的效率，空氣的淨化功能也將降低，因此需要有計劃的定期清潔過濾網；清潔的頻率則依賴於機器的運行的狀況和運行的持續時間；如果機器經常使用或者連續地運行，推薦您至少一周清潔一次。

取出過濾網時，先按下圖所示，拉出格柵(如右圖)，再取出濾網。

為了避免可能的人身傷害，移除或安裝濾網時，請不要觸碰機器內部的金屬部件。

使用吸塵器除去過濾網上的堆積的灰塵；如果過濾網太髒，使用溫水多次漂洗，水溫不可超過 40°C；過濾網清洗完後，確保它徹底晾乾再裝入機器。

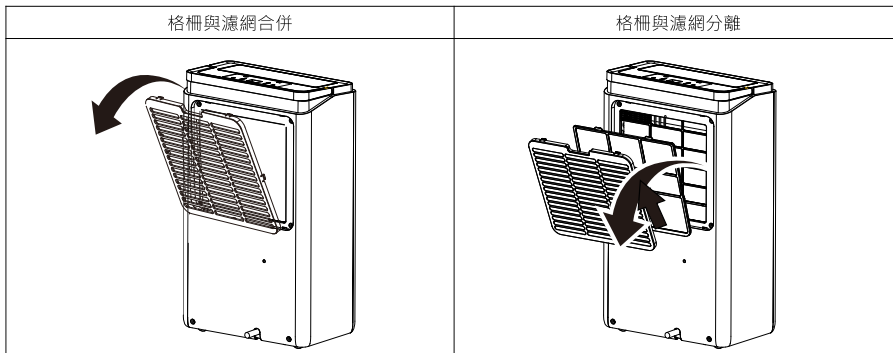
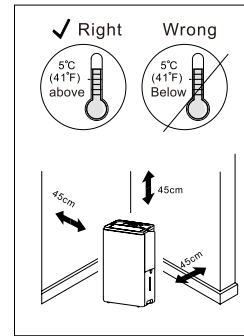

- 如果機器長時間不用：

拔出主電源插頭，並清空水箱裡面的水，清潔過濾網並重新放置好，遮蓋該電器以防止沾滿灰塵，直立放置在乾燥的地方。

- 長時間存放後，開始使用前：

檢查並確保電源線及插頭沒有破損，接地良好。
重新按上述方法連接電源及操作。

● 常見故障

問題	可能原因	解決方法
抽濕機不啟動	抽濕機沒有電源	確保抽濕機電源插頭插入插座上
	保險絲斷了·斷路器斷路	檢查房子保險絲/斷路器箱·更換保險絲或復位斷路器
	抽濕機已經達到了現在的濕度水準或水箱水滿	設置為較低的濕度水準或清空水箱並安裝正確
	水箱安裝位置不當	水箱必須正確地安裝
	電源故障	有一個保護延遲時間(約 3 分鐘)來防止壓縮機超載斷路·因為這個原因·在啟動後約 3 分鐘內抽濕機可能無法啟動壓縮機
抽濕機不抽濕	沒有足夠的時間允許設備來去除水分	第一次使用時·至少必須要運行 24 小時後來保持所需的乾燥度
	空氣不流通	確保沒有窗簾·百葉窗或傢俱擋在抽濕機的前面或後面·見“位置選擇”章節
	過濾網過髒	見“清潔濾網”章節
	濕度設置可能不夠低	空氣比較乾燥·按“  %”鍵控制室內所需的濕度·或設置到“CO”可達到最大的除濕
	門窗可能沒有完全被關閉	把所有門窗和其他的開口關閉
	衣物烘乾機可將潮濕空氣吹進房間	安裝抽濕機時要遠離衣物風乾機
	房間的溫度太低	提高房間溫度
抽濕機運行太久	抽濕機所處的區域太大	抽濕機的除濕能力不能滿足房間大小
	有門窗打開	關閉門窗
兩器上有霜出現	抽濕機最近啟動過或房間溫度太低	這是正常的·霜通常會在 60 分鐘內消失
風扇有雜訊	空氣正在通過這個設備	這是正常的
水流在地板上	排水管可能老化	檢查排水管及接頭是否有漏水
	排水管已連接·但水排不出	檢查並重新連接排水管·使其平順

- 如果出現以下故障代碼·請聯繫售後服務部門進行檢查維修·

故障代碼	故障描述
EH	濕度感測器故障
E1	溫度感測器故障
E2	

gemini
ITALY

Wi-fi功能使用說明書



使用本產品前請仔細閱讀，並妥善保管，以備查閱！
如有疑問請與服務中心或經銷商聯繫。

Wi-fi應用程式使用說明

請掃描QR 碼以便下載最新版本應用程式



iOS



Android



多謝選用我們的抽濕機。

此說明適用於備有Wi-fi 功的抽濕機。

請仔細閱讀此使用說明，並妥善保管以備查閱

請勿自行移除Wi-fi 模組。

因為技術更新，可能出現實物同使用說明出現差異。請參考實物。

安裝應用程式

完成下載應用程式，請安裝於您的智能手機上。

當完成安裝後，你可於手機找到“”標誌的應用程式。

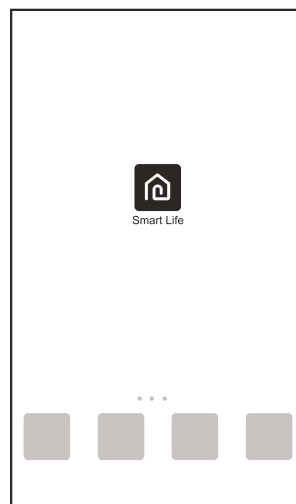
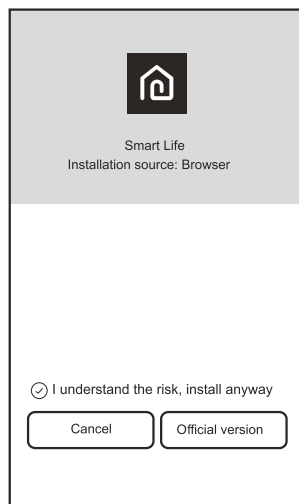

啟動QR碼

1. 當您首次使用應用程式時，介面會顯示啟動頁面而您需要掃描QR碼(按掃描鍵並掃描下頁的啟動QR碼或輸入啟動碼以完成啟動工作。

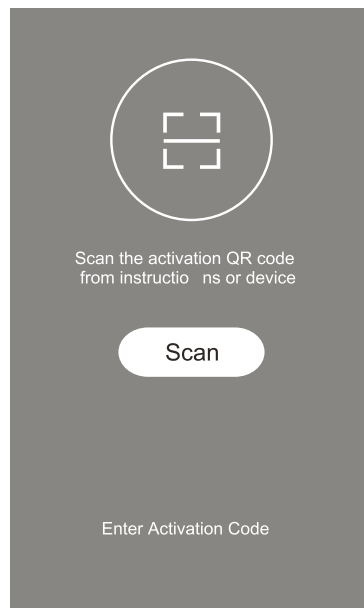

2. 抽濕機啟動QR碼



3. 輸入啟動碼“ gemini ”

登記使用戶口

當您首次使用應用程式時，需一併註冊使用帳戶。按下註冊鍵進入註冊介面，你可以用電郵或手機號碼進行註冊。

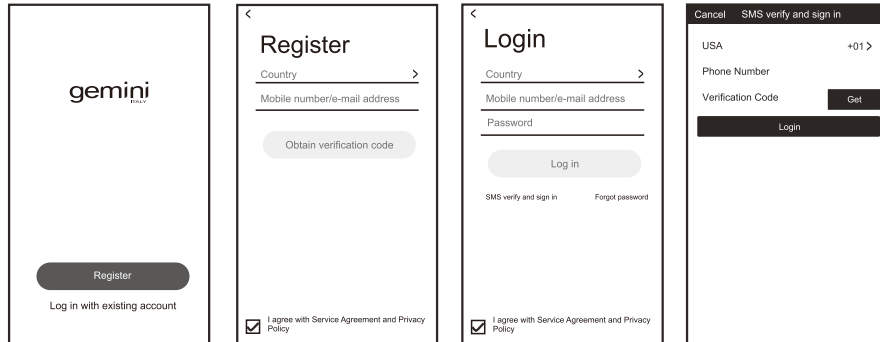

登入使用戶口

1. 登入已註冊的戶口，請填入已註冊的電郵或手機號碼及密碼，然後按下登入鍵。
2. 如以手機號碼登入，請按以“SMS短訊登入”以便進入下一頁，填寫電話號碼並“取得”鍵接受確認號碼，填入後，再按“登入”鍵。

忘記密碼

1. 按下“忘記密碼”去下一頁。
2. 填入登記手機號碼及電郵地址後，按“下一頁”去下一頁。
3. 你會收到確認碼，填入後並填上新密碼後，按“確認”鍵。

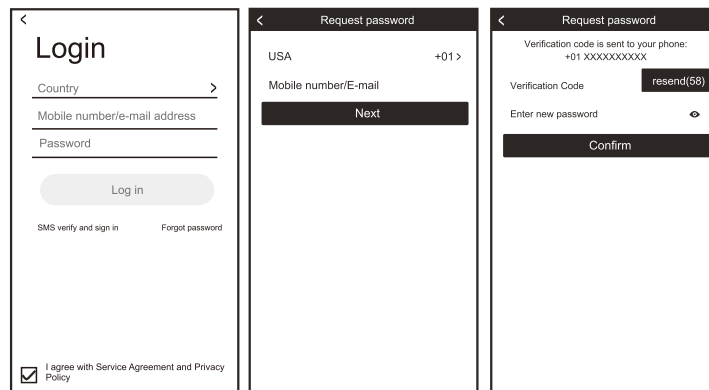

ADD THE DEVICE 增加裝置

1. 按下“增加裝置”鍵到下一頁，選擇產品類別。
2. 這有兩種方法去進行裝置對接，“CF或AP模式”透過選擇兩個不同鍵執行。

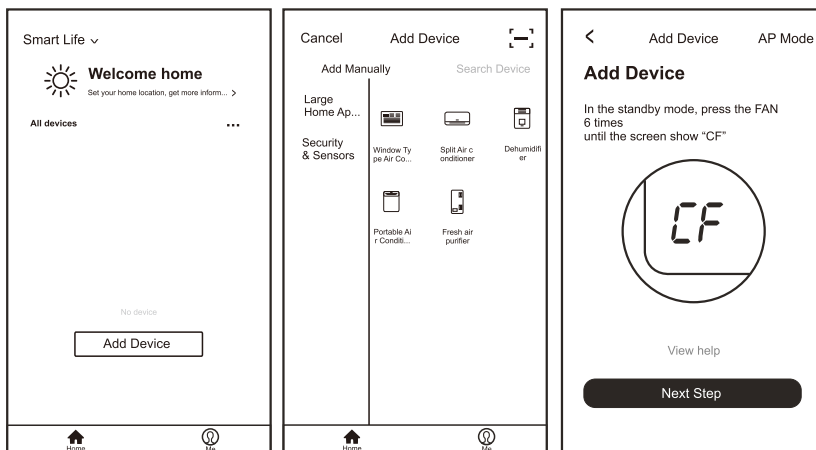

增加裝置 (CF模式)

1. 系統設定以“CF”模式優先，按“下一步”去繼續。
 2. 選擇路由器，填入路由器密碼。按下“下一步”去繼續。
 3. 在待機模式下，在4秒內連續按下操控面板上的“定時”按鍵6次直至出現“CF或AP”。
- 此為Wi-Fi重設，以進行“CF”和“AP”模式互換。

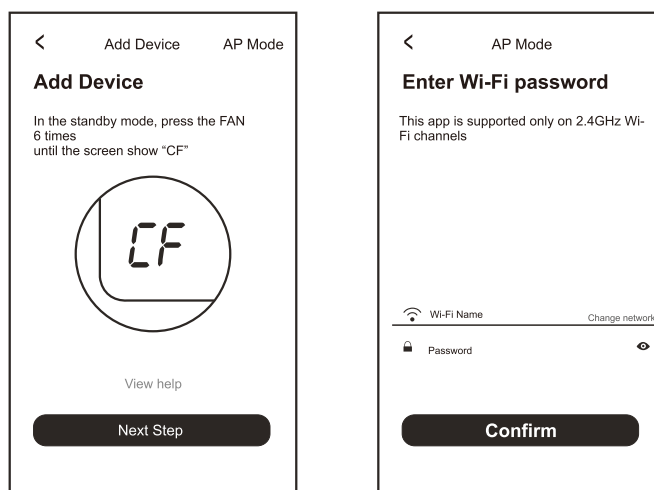

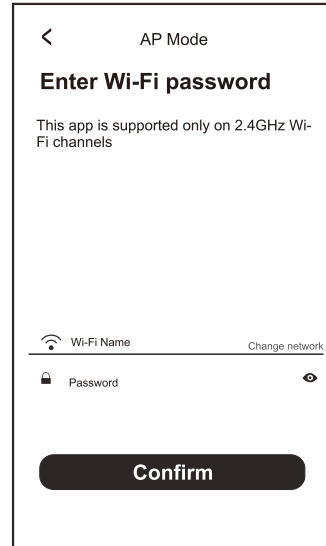
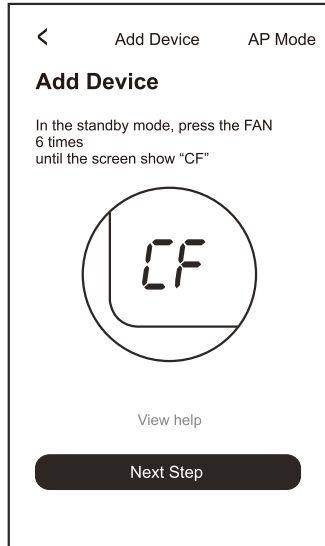

4. 應用程式會進行自動掃描進行裝置對接。
5. 當完成對接後，會出現以下畫面。
6. 你可以“重新命名”裝置以便分享給其他使用者。或按“完成”以開始操作裝置。

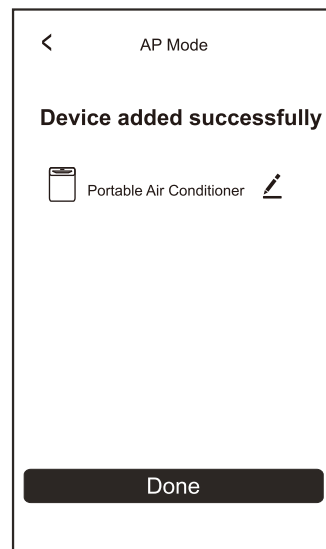
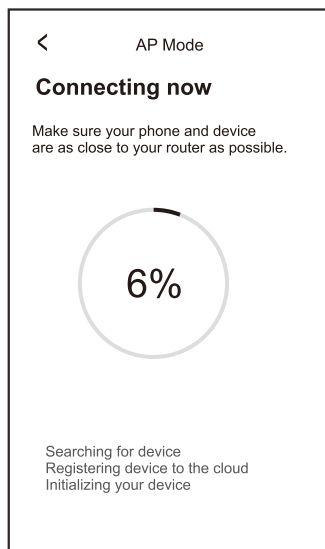

增加裝置 (AP模式)

1. 按下“AP”模式進入“AP”頁面。然後按下“下一步”去繼續。
2. 選擇路由器，填入路由器密碼。按下“下一步”去繼續。
3. 在待機模式下，在4秒內連續按下操控面板上的“定時”按鍵6次直至出現“CF或AP”。此為Wi-Fi重設，以進行“CF”和“AP”模式互換。

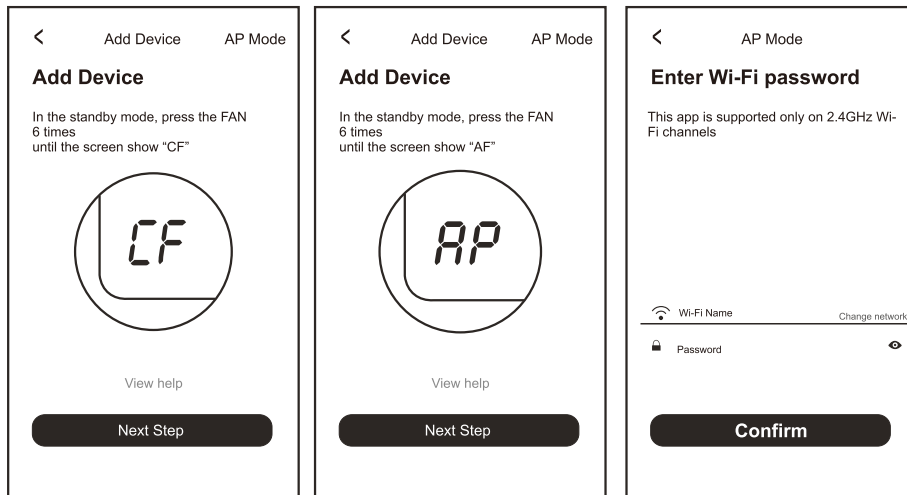

4. 選擇在網絡設定上的裝置 “Smart life-XXX” ，然後回到應用程式的介面。應用程式會進行自動對接。

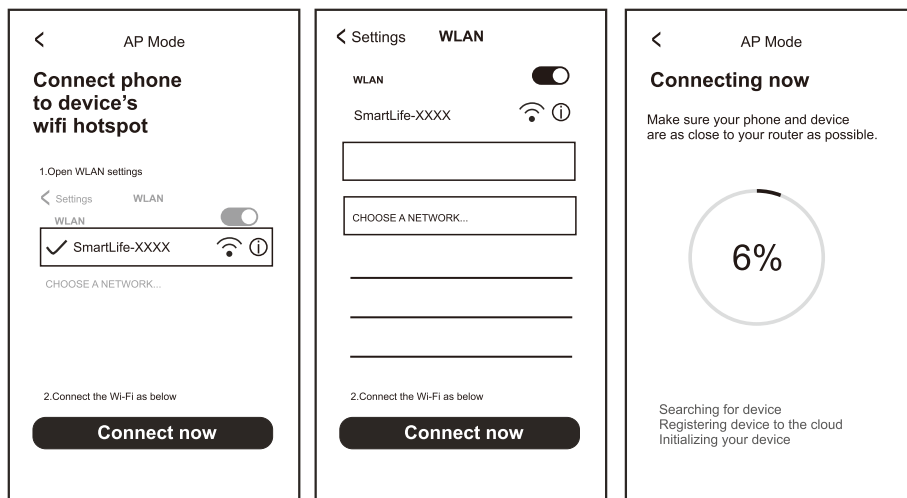

5. 當完成對接後，會出現以下畫面。

6. 對應失敗後，應用程式會作出提示然後請按 “重試” 再作出連接。

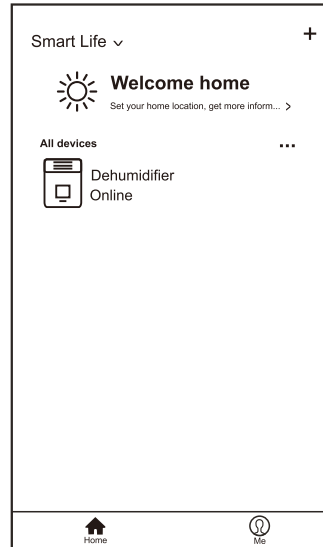
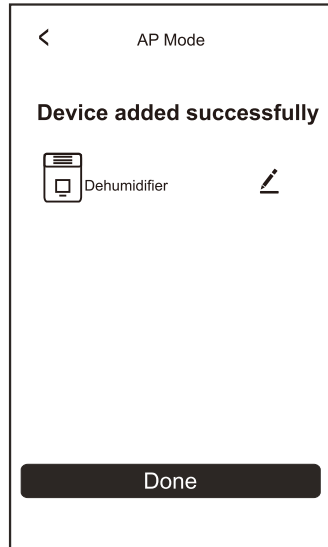

抽濕機控制

1. 按下抽濕機裝置名稱進入操控介面，按下“開/關”然後調節濕度。

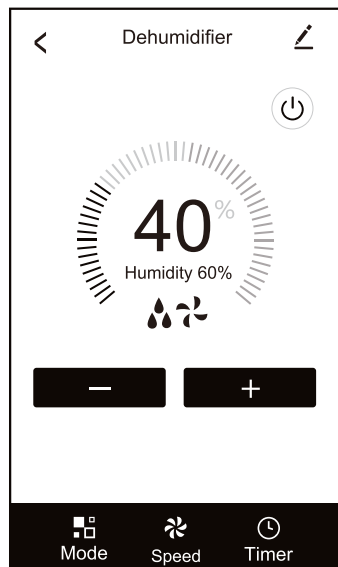

*因為應用程式更新，可能出現實物同使用說明出現差異。請參考實物。

2. 如出現 “ EH、E1” 顯示，則為濕度感應器故障。請與服務中心聯繫作出檢查及維修安排。

ERROR CODE

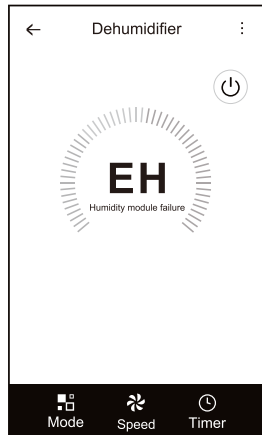

ERROR CODE

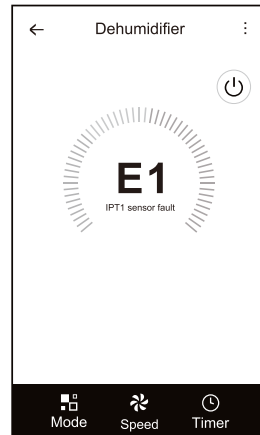

3. 如出現 “ ”  顯示，則為水箱滿載。請清空水箱並妥善放回。

ERROR CODE

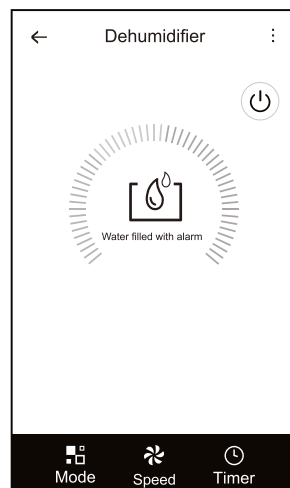

4. 設定時間擊功能，按下“時間擊”按鍵進入應用程式時間設定介面。介面內有排程表列出先前設定的時間(如有安排)，你可以長按按鍵作出修改或加入新排程。

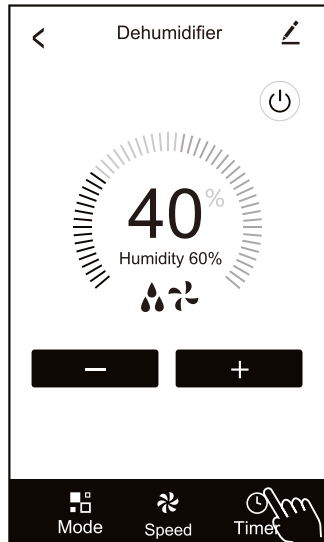

5. 按下“開”或“關”鍵去設定時間擊開關。

你可以設定小時, 分鐘模式，風扇速度等。完成按鍵確認或取消。

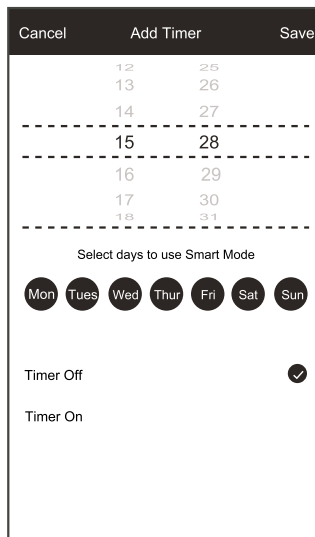

6. 在右上角位置，你可以進行多項功能設定，如: 更正裝置名稱，裝置分享，裝置資訊，反饋，版本更新檢查，移除裝置及還原出廠設定。

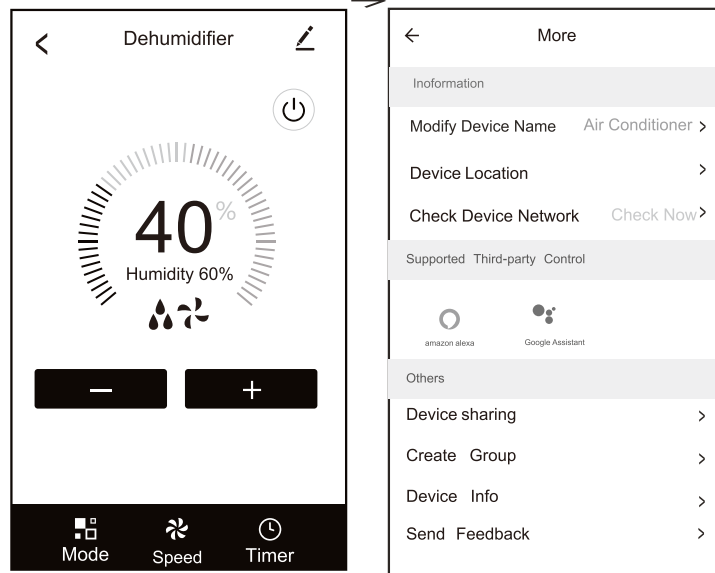

7. 資料

你可以管理個人資料。包括:

- a. 戶口資料
- b. 掃描QR碼: 開發者可以預覽操控介面。
- c. 分享裝置: 顯示使用者裝置分享資訊
- d. 訊息中心: 顯示系統發給使用者的訊息。
- e. 反饋: 使用者可以提供線上反饋。
- f. 關於: 提供現有應用程式版本。

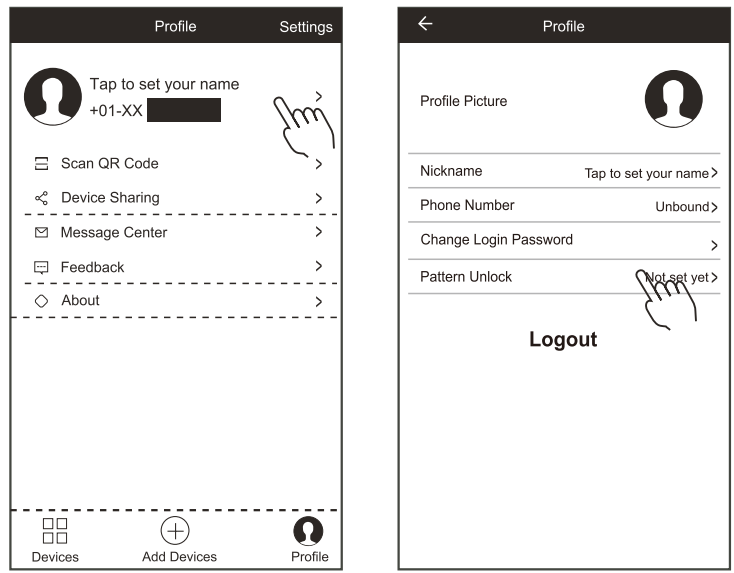

8. 模式解鎖: 按下 “模式解鎖” 去設定你的應用程式解鎖模式。

完成後，你可以按此方法解鎖應用程式。

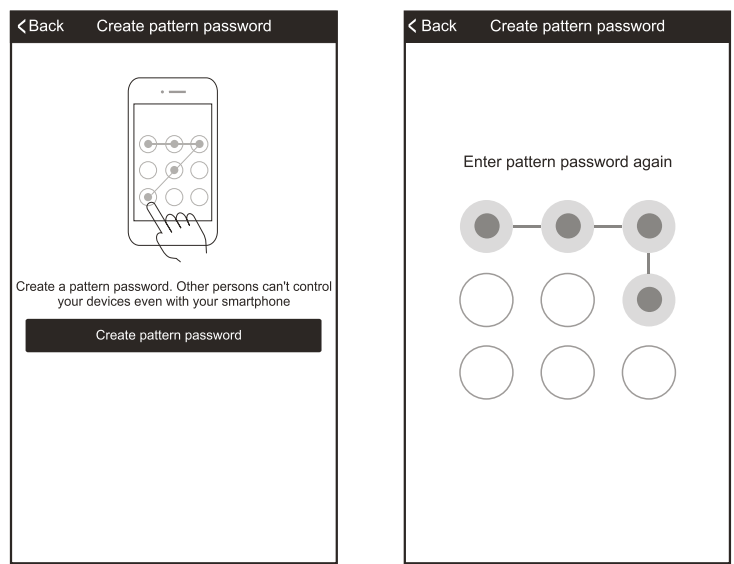

● 常見故障

問題	可能原因
抽濕機不能成功設定	1. 檢查手機連接Wi-Fi地址及其密碼是否正確。 2. 檢查抽濕機是否在設定狀態下。 3. 路由器及網絡是否設有防火牆及其他限制。 4. 檢查路由器是否正常運作。 5. 確認抽濕機, 路由器及手機是否在訊號覆蓋範圍。 6. 檢查路由器是否屏蔽應用程式。
手機不能控制抽濕機	軟件顯示: 識別失敗 表示抽濕機被重設, 手機失去控制權。需要重新連接Wi-Fi 寺取得控制權。 請重新連接網絡並更新連接, 如執行後仍未能正常運作則要取消設定重新設定。
手機不能找到抽濕機	軟件顯示: 抽濕機斷線。 請檢查網絡狀態 1. 抽濕機被重設 2. 抽濕機未有連接電源 3. 路由器斷電 4. 抽濕機未能連接路由器 5. 抽濕機未能經由路由器連接網絡(AP模式) 6. 手機未能未能連接路由器 7. 手機未能經由路由器連接網絡(AP模式)

請記錄下列產品資料

型號 Model No.:

機身編號 Serial No.:

經銷商名稱 Dealer:

購買日期 Date of Purchase:

單據編號 Invoice No.:

本產品不斷改進中，如功能有所更改，恕不另行通知
如有疑問，請與客戶服務中心聯絡。不便之處，敬請原諒。

The product specifications may be changed without prior notice.
Please contact customer service for details if necessary.

說明書內容以英文版本為準

If there is any inconsistency or ambiguity
between the English version and the Chinese version,
the English version shall prevail.



保養登記
Warranty Registration

於網上登記新產品保養 Register your product online
www.dchtoolbox.com



客戶服務中心 DCH ToolBox Customer Service Centre
香港九龍灣啟祥道20號大昌行集團大廈4樓
4/F, DCH Building, 20 Kai Cheung Road, Kowloon Bay, Hong Kong

客戶服務熱線 Customer Service Hotline: (852) 8210 8210
電郵地址 E-mail: 8210service@gilman-group.com
網址 Website: www.gilman-group.com