

gemini

ITALY

Dehumidifier User Manual

抽濕機使用說明書

GDW13W

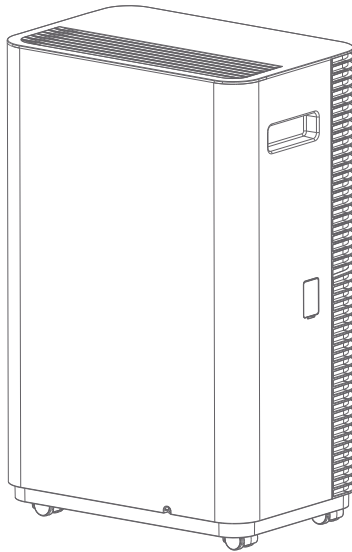

Please read this user manual carefully before using and retain it for reference.

使用本產品前請仔細閱讀，並妥善保管，以備查閱！

If have queries, please contact the service center for support.

如有疑問請與服務中心或經銷商聯繫。

安全須知



此符號表示本設備使用高度易燃製冷劑。若製冷劑洩漏和暴露於外部火源，有機會引起火災。

注意，有火災危險



使用和保養產品前，請細閱本說明書，並妥善保管。



此符號表示使用說明書備有該資訊。



此符號表示維修人員應參考本使用說明書，以操作本設備。

為免使用者或他人受傷，以及財產損失，請務必跟隨以下說明。因忽略說明而導致的錯誤操作，可能造成傷害或損壞。

• 嚴重性按以下標示分類。

⚠ 警告 此符號表示可能導致死亡或重傷。

⚠ 注意 此符號表示可能造成傷害或財產損失。

• 本手冊中使用的多個符號之含義如下所示。

🚫 帶此標誌的內容，表示禁止行為。

⚠ 帶此標誌的內容，表示應該遵守。

⚠ 注意

- 8 歲及以上兒童，以及上述生理、感知或智力能力不足，或缺乏經驗和知識的人士可以在接受有關安全使用本裝置的監督和指導，並理解本裝置所含風險的情況下使用本裝置。兒童不得將本裝置當作玩具使用。兒童不得在無人監督的情況下清潔本裝置及為其進行用戶維護。
- 本裝置不適合生理、感知或智力能力不足，或缺乏經驗和知識的人士（包括兒童在內）使用，除非其安全負責人向其提供有關使用本裝置的監督或指導。
- 如不嚴格遵守，可能導致人身傷害或死亡等嚴重事故。
- 兒童應受監護，以確保兒童不嬉玩電器。
- 不要擅自更換電源線或將電源線中途駁接，如果電源線損壞，為了避免危險，必須由製造商、其維修部或類似部門的專業人員更換。
- 對抽濕機進行清潔時，請停止運行機器，並關閉電源開關。
- 為了防止火災、爆炸或傷害，當附近可能有可燃性或腐蝕性氣體時，不得使用抽濕機。
- 不要將抽濕機放置在熱源附近，否則可能會導致器件變形或引發火災。
- 不要擅自修理、拆解、改裝或清潔內部器件，處置不當會導致漏水、觸電、火災等。需要修理時，請撥打服務電話。
- 不要將手指、棍棒或其他物品伸到進風口或出風口中，否則可能會造成產品故障或損壞，甚至人身傷害。

- 手濕時不要操作抽濕機、插拔電源線，以免造成觸電。
- 不要用水直接清洗抽濕機或在可能會接觸到水的場所使用抽濕機，否則可能會導致觸電或火災。
- 不可在抽濕機上放置有水的容器，如花瓶等，否則可能會導致觸電或火災。
- 處理和保養抽濕機前，請關掉抽濕機和拔除電源插頭，以免觸電或火災。
- 本設備僅具備功能的接地線。
- 請勿超過電源插座或連接設備的額定值。否則，本設備可能會因產生過熱而導致觸電或火災。
- 請勿修改電源線長度或與其他裝置共用電源插座。這可能產生過熱，而導致觸電或火災。
- 請勿飲用或使用抽濕機排放的水。當中含有污染物，可能致病。
- 水箱接觸開關不會關閉抽濕機電源，而造成觸電危險。設備運作時，請勿取出水箱。

⚠ 如果發現異常現象（如燒焦的氣味等），應立刻切斷電源，並撥打服務電話尋求解決方法。在此情況下仍繼續使用，會導致損壞、觸電、火災。

⚠ 警告

- 除製造商建議外，請勿採用加速除霜過程或清潔方法。
- 本電器應貯存於沒有持續運作火源的房間內，例如明火、運作中的氣體用具或運作中的電暖爐。
- 請勿刺穿或燃燒。
- 請注意，製冷劑含異味。
- 本設備應在建業面積 4 平方米以上的房間內安裝、操作及貯存。

- 製冷劑管道的安裝空間，應符合國家及當地法律規定。
- 請保持通風口暢通無阻。
- 貯存本電器時，應避免機械損壞。
- 任何參與製冷迴路工作或維修的人員，均須持有由業界認可評估機構/製造商/代理商頒發的有效證書，以茲證明他們具備安全處理製冷劑所需的必要資格。
- 請僅按照製造商建議的方法保養和修理抽濕機。如需其他技術人員協助作保養或修理，應由具備處理 R290 製冷劑資格的人士監督。
- 請在通風良好的房間貯存本設備，這房間大小應相對指定操作房間面積。
- 所有影響安全措施的工作程序，僅由合資格人士執行。

⚠ 注意

如不嚴格遵守，可能導致人身傷害或物品損壞等事故。

- ⊘ ● 不要攀爬或坐靠在抽濕機上，否則可能會導致零件變形。
- 不要讓抽濕機直吹植物或動物，否則可能會引起不良影響。
- 不得將有明火的物體放在抽濕機的出風口，否則可能會因為燃燒不完全產生有毒氣體。
- 不要遮擋抽濕機的進風口、出風口，否則可能會降低抽濕機使用性能或發生故障。
- 長期不使用時，請關閉電源開關，將水箱清潔晾乾後裝回主機，整機通風放置兩天後再進行收納。
- 抽濕機器內有壓縮機，須直立放置，如有傾倒或經長途運輸，請把機器至少直立放置4小時後再通電開機。
- 請勿在狹小空間內使用抽濕機。通風不足，會導致過熱和火災。
- 請勿在處理化學品的場所內使用抽濕機。這是因為化學品和溶劑可能溶解於空氣中，而對抽濕機造成損害。
- 請勿在電源線上放置重物，並確保電源線不受擠壓，以免火災或觸電危險。

- ⚠ ● 請勿在洗衣間使用抽濕機。
- 如果水管的周圍溫度低於零度，請勿連續排水。
- 請勿在地毯上拖動機器，否則可能發生傾倒的危險。
- 請將抽濕機放置於穩固的水平地面，否則可能會影響機器使用效果。
- 請經常清潔抽濕機空氣濾網，濾網積堵可能會導致抽濕效果降低。
- 請勿將機器靠在障礙物或牆上，機器周圍必須留有至少20公分的空間，出風口上方必須留有至少50公分的空間。
- 抽濕機在一個相對封閉的有效空間內使用方可達到最佳性能，使用機器時請關閉門窗以及其他通風裝置。
- 若有水進入抽濕機，請關掉抽濕機和拔除電源，然後聯絡合資格維修技術人員。否則，這可能會導致抽濕機故障或造成意外。
- 抽濕機安裝應符合國家及當地法規。
- 內置電暖爐的設備，應與可燃物品相距最少 1 米。
- 如需維修或保養本抽濕機，請與授權維修技術人員聯絡。
- 若電源插座鬆脫或損壞，請勿使用。
- 請勿將本抽濕機用於本使用說明書所述以外的其他用途。
- 如欲安裝抽濕機，請與獲授權安裝人員聯絡。
- 如遇雷雨，請務必拔除抽濕機電源，以免遭雷電擊中而損壞。
- 請勿將電源線放在地毯下。請勿以小地毯、滑道或類似覆蓋物覆蓋電源線。請勿在家具或設備下方放置電源線。請在遠離走道和在不會絆倒他人的地方放置電源線。
- 抽濕機運作時，請勿打開抽濕機水箱。
- 拆卸過濾網時，請勿觸摸抽濕機的金屬零件。
- 拔除電源線時，請緊握電源插頭。

電力資料

- 本抽濕機背板貼有製造商的標示牌，載列本抽濕機的特定電力和其他技術資料。
- 請確保抽濕機的地線接駁妥當。請務必妥當連接地線，將觸電和火災風險降至最低。本電源線配備三腳接地插頭，可避免觸電危險。
- 抽濕機必須在正確接上地線的牆壁插座中使用。若您打算使用的牆壁插座欠缺適當的地線或延時保險絲或斷路器的保護，這可能導致觸電和火災。所需延時保險絲或斷路器以抽濕機最大電流而定，抽濕機標示牌載列最大電流資料。請確保由合資格的電工安裝符合規格的插座。
- 請確保安裝抽濕機後可使用該電源插座。
- 請勿將本抽濕機連接延長線或電源轉換插。可是，如須使用延長線，請僅使用經認可的抽濕機延長線（當地各大五金舖有售）。
- 安裝和/或維修前，請務必中斷抽濕機電源，以免造成受傷危險。
- 請務必嚴格按照抽濕機電箱上的電線連接圖接駁所有電線。

保險絲規格

抽濕機的電路板 (PCB) 設計備有保險絲，可提供電流過量保護。電路板上印有保險絲規格，如：T 3.15 A/250 V (或 350 V) 等。
碳氫化合物注意事項：

- 密封設備內含碳氫化合物。該抽濕機製冷劑所使用的碳氫化合物、氣體量和二氧化碳等值量（以噸為單位）的具體資料，請參閱抽濕機上的相關標籤。
- 本抽濕機的安裝、工程服務、保養和修理，必須由認可技術人員進行。
- 本抽濕機的拆卸和回收，必須由認可技術人員進行。

產品介紹

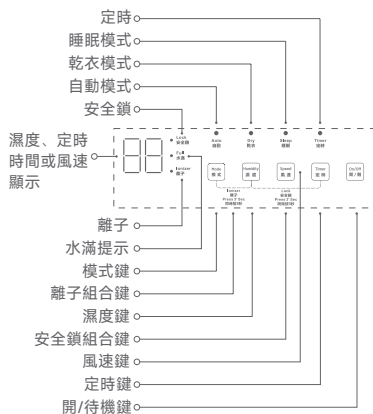
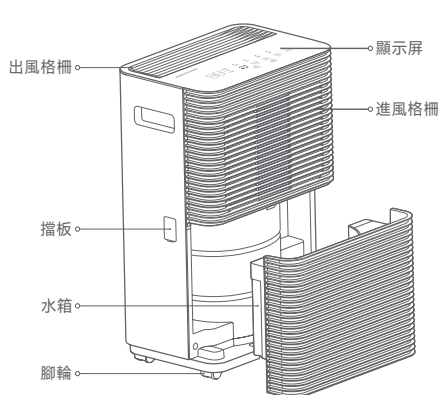

提示：說明書中的產品、配件、用戶介面等插圖均為示意圖，僅供參考。
由於產品的更新與升級，產品實物與示意圖可能略有差異，請以實物為準。



使用

開/待機

- 短按  鍵，開機或待機。
- 待機烘乾：為減少機身內部水氣，待機前會進行40分鐘烘乾，烘乾結束後待機；烘乾過程中短按  鍵可強行待機。

切換模式

開機狀態下，短按  鍵回圈切換：自動、睡眠、乾衣模式。



自動模式：抽濕機根據室內濕度與設定目標濕度，自動調整工作狀態，自動調節風速。

乾衣模式：抽濕機以高風速、強力除濕的方式持續運行，不可設定目標濕度。為達到最佳的乾衣效果，建議衣服脫水後，在密閉房間內使用乾衣模式。

睡眠模式：抽濕機根據室內濕度與設定目標濕度，自動調節節停。

提示：自動模式下，可自行設定目標濕度及風速，若自行設定，則自動指示燈會熄滅進入自定義設定狀態。

睡眠模式下，抽濕機運行會有正常工作噪音，建議與牀鋪保持一定距離放置或在睡前關閉設備，避免影響休息。

本產品整體噪音較低，不同工作模式下，噪音差異不明顯，此屬正常現象。

設定目標濕度

自動或睡眠模式下，短按  鍵循環切換目標濕度：40%→45%→50%→55%→60%→65%→70%→75%→80%。

設定風速

智能模式下，短按  鍵循環切換風速：AU（自動）→F1（低風速）→F2（高風速）。

定時功能

待機狀態下可設置定時開機，開機狀態下可設置定時待機。

短按  鍵選擇定時開/待機時間，定時區間為1小時，可設定時間範圍為1-12小時。定時設置時，定時指示燈常亮。

離子功能

同時長按  和  鍵3秒，開啓或關閉離子功能。功能開啓時，顯示屏上顯示  圖標。

安全鎖功能

同時長按  和  鍵3秒，開啓或關閉安全鎖功能。功能開啓時，顯示屏上顯示  圖標，此時抽濕機不響應其他按鍵操作。

水滿保護

在運行狀態下，當水位超出水箱上水位線或者水箱安裝不到位時，抽濕機會觸發水滿保護，此時蜂鳴器會發出5次“嘀”的響聲，顯示幕上水滿

提示圖示  持續閃爍，除開/待機鍵外所有按鍵失效。水位恢復正常且水箱安裝到位時，水滿提示圖示  熄滅，抽濕機恢復正常。

提示：出現水滿提示後請及時減少水箱水量，安裝好水箱。

除霜功能

抽濕機運行過程中，蒸發器和冷凝器出現冰霜覆蓋時，會自動進入除霜狀態，壓縮機停止運轉，風機繼續運行直至除霜結束。

處於除霜狀態時，顯示屏上    圖標緩慢閃爍，除霜結束後，模式圖標恢復常亮，除濕機進入正常運行狀態。

連續排水

1. 拉住水箱水準向外抽出。

2. 取下水箱上的擋板。

3. 連接排水管。

4. 裝回水箱，將排水管的另一端連接至下水道，此時抽濕機可以自動排水。

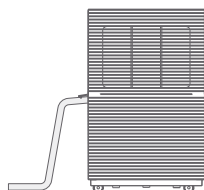
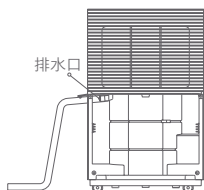
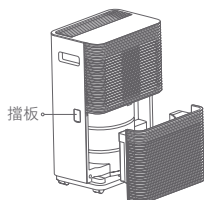
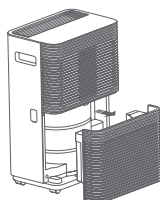

提示：使用連續排水時，排水管末端應低於抽濕機排水口，且嚴禁高低不平及過度彎折，以確保水順暢排出。

維護與保養

△ 注意

- 清潔抽濕機前必須停機並斷開電源，以免發生觸電危險。
- 請勿沖洗或將抽濕機浸泡在液體中，請勿將水滴入抽濕機。
- 不要使用揮發性液體（如稀釋劑、汽油等）擦拭抽濕機，否則可能會損壞抽濕機外觀。先用沾有中性洗滌劑的濕布清潔抽濕機外殼，然後用柔軟的乾布擦拭一遍。
- 定期清潔過濾網，以免灰塵覆蓋影響使用效果。在灰塵較多的環境中使用抽濕機時，應增加清洗次數。取下過濾網後，不要用手指觸摸殼體內的翅片部分，以免劃傷手指。

清潔機身

使用45°C以下的溫水將布浸濕，擰乾後輕擦髒污部分。

清潔過濾網

1. 握住水箱底部的把手往外水平抽出水箱，從進風格柵底部往下抽出過濾網。

2. 用水漂洗或用吸塵器清理過濾網及進風格柵，過濾網很髒(如有油污)時，需用溶有中性洗滌劑的溫水(45 °C 以下)清洗，然後放置於陰涼處晾乾。

依次裝回過濾網、水箱。

提示：安裝過濾網時，注意圖示方向標

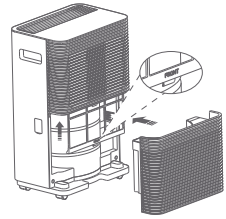
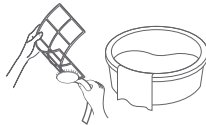
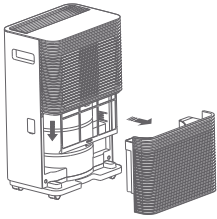

清潔水箱

1. 握住水箱底部的把手往外水平抽出水箱。

2. 按住水箱倒水口用力，可輕鬆拆下水箱蓋。

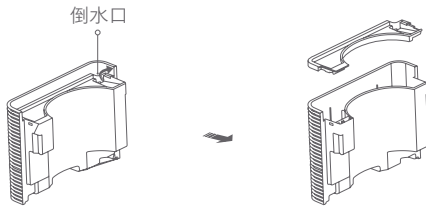

3. 將水箱清洗乾淨並晾乾，之後將水箱蓋裝好，將水箱復位。

長期儲存

1. 待機並斷開電源後，請靜置兩天。
2. 清潔主機、水箱及過濾網。
3. 請將電源線理順整理並用電源線紮帶綁好。
4. 建議使用包裝袋將抽濕機裝好。
5. 將抽濕機直立儲藏在乾燥通風處。

故障排除

故障現象	可能原因及解決方法
開待機或工作時機身突然抖動	<ul style="list-style-type: none">● 壓縮機啟停導致，屬於正常現象。
抽濕效果不佳	<ul style="list-style-type: none">● 建議在5°C~35°C的室內環境使用。● 檢查濕度設定是否合適。● 檢查進、出風口是否有髒污及堵塞，請及時清理。● 檢查門窗是否打開，建議關閉門窗及通風設備。
抽濕機無法運行	<ul style="list-style-type: none">● 檢查電源插頭是否鬆脫及室內是否停電。● 檢查水箱是否水滿或者水箱是否安裝好。● 檢查是否使用了定時功能。
抽濕機漏水	<ul style="list-style-type: none">● 檢查排水管是否鬆脫。● 可能是排水系統堵塞，請聯繫售後。
運行時有異常的聲音	<ul style="list-style-type: none">● 檢查機器是否放置平穩。● 檢查過濾網是否堵塞。● 可能是壓縮機啟動時的冷媒聲音，屬於正常現象。
水箱內部出現黑色污漬	<ul style="list-style-type: none">● 抽濕機蒸發器和冷凝器表面附著的材料混合著空氣中的灰塵隨冷凝水流進水箱，形成黑色污漬，屬於正常現象。● 可直接用紙巾等擦除，該現象會隨使用時間增加逐漸緩解

錯誤代碼說明

代碼	可能故障	解決方法
C2	風機故障	斷開電源，5分鐘後開機。如故障代碼多次出現，請聯繫售後。
C3	顯示板與主板通訊故障	斷開電源後重新開機。如無法解決，請聯繫售後。
E1	管道感溫器故障	斷開電源，5分鐘後開機。如故障代碼多次出現，請聯繫售後。
E9	濕度感測器故障	斷開電源，5分鐘後開機。如故障代碼多次出現，請聯繫售後。
H2	超載保護	檢查進、出風口是否堵塞，清理後重新開機。如故障代碼多次出現，請聯繫售後。
H6	缺氧保護	斷開電源，5分鐘後開機。如故障代碼多次出現，請聯繫售後。
H8	超溫保護	請確保在5°C~35°C的環境溫度下使用。如仍然報故障代碼，請聯繫售後。

提示：故障代碼會顯示在顯示器上。

基本參數

- 抽濕量在其所標定環境溫度、濕度時測得，隨著工況的變化而會有所變化。
- 工作溫度範圍為5°C-35°C，若室溫超出此範圍，抽濕機可能不工作。
- 如參數數據有變更，則以產品銘牌的參數為準，恕不另行通知。

產品名稱：Gemini抽濕機

額定電壓：220-240 V-

額定頻率：50 Hz

製冷劑：R290/0.046 kg

額定輸入功率：185 W

最大輸入電流：1.30 A

輸入功率：145 W (26.7°C/60%相對濕度)

165 W (30°C/80%相對濕度)

抽濕量：7 公升/天 (26.7°C/60%相對濕度)

13.5 公升/天 (30°C/80%相對濕度)

產品型號：GDW13W

噪聲：≤38 dB(A)

產品淨重：10.8 kg

風量：125 m³/h

水箱容積：1.8 L

產品尺寸：290 × 455 × 195mm

工作溫度：5°C-35°C

熔斷絲規格：T3.15 A/250 V

電源線規格：3 × 0.75 mm²

警告：器具的安裝、運行、儲存的房間面積應大於4 m²。

維修安全注意事項

警告

- 如需維修或報廢抽濕機，請撥打服務電話。
- 本抽濕機使用R290製冷劑，禁止由非專業人士進行維修。
- 有關裝有易燃製冷劑設備的運送
請參閱運送規定。
- 請注意設備上的標誌
請參閱當地法規。
- 請採用易燃製冷劑設備的廢物處理
請參閱國家規定。
- 設備/電器貯存
設備貯存應按照製造商說明進行。
- 包裝妥當（未售出）設備的儲存
 - 組合儲存包裝保護時，應確保包裝內設備如遇機械損壞，也不導致製冷劑洩漏。
 - 最大允許設備儲存量以當地法規而定。
 - 特別製冷劑在系統中循環，以執行抽濕機功能。這過程所用的製冷劑，為R290（丙烷），屬高度易燃。
 - 該製冷劑除了易燃，也帶有異味。此外，它在某些情況下，可能導致爆炸。
 - R290與一般製冷劑相比，既是一種無污染製冷劑，也對臭氧層無害。除此，它對溫室效應影響也較小。因為R290具備良好熱力學特性，所以帶來高能源效率。因此，這些機組需要較少填充物。
- 維修人員資格
 - 所有作業人員或製冷回路維修人員都應獲得行業認可的評估機構/製造商/代理商頒發的有效證書，以認定其具備行業認可的評估規範所要求的安全處置製冷劑的資格。
 - 只能按照設備製造商推薦的方法進行設備的維護和修理。如果需要其他專業人員協助維護和修理設備，則應在具備使用R290製冷劑資格的人員監督下進行。
- 對場地的檢查
使用R290製冷劑的抽濕機進行維修前，必須進行安全檢查，以確保發生著火的風險降到最低。維修製冷系統時，在對系統進行處理作業前，應遵守下麵所述的安全注意事項。
 - 作業程式
應當在受控的程式下進行作業，以確保進行作業過程中由可燃性氣體或蒸汽所引發的風險最低。
 - 一般作業區域
在作業區域內的所有維修人員以及其他人員應該知道所從事作業的性質，應避免在密閉空間內作業。作業區域應適當隔離，通過控制可燃材料以確保作業區域內的工作條件的安全。

· 檢查製冷劑是否存在

作業前和作業過程中應適當使用適當的製冷劑監測儀在區域內監測，以確保技術人員意識到存在潛在可燃性氣體。確保所使用的檢漏設備適用於可燃性製冷劑，如：無火花，充分密封或是本質是安全型的。

· 滅火器的放置

對製冷系統或相關部件進行熱加工作業時，應將適用的滅火器置於就近處。製冷劑注入區域應配備乾粉或二氧化碳滅火器。

· 禁止火源

從事與暴露在外之容納有或曾經容納可燃性製冷劑的管路相關的工作時，不應使用可能引起著火或爆炸危險的各種形式的火源。所有火源，包括吸煙在內，若可燃性製冷劑有可能釋放到周邊環境，一定要遠離安裝、修理、移機、處置的區域，在開始作業前，要對於設備周邊環境進行檢查以確保沒有易燃或著火的危險。應設置“禁止吸煙”的標記。

· 通風的區域

確保在打開系統或進行熱加工作業前，作業區域是開放的或是充分通風的。在作業過程中應保持通風，通風將安全地稀釋洩漏的製冷劑並迅速排放到大氣中。

· 製冷設備的檢查

· 如果更換電氣元件，這些電氣元件應按照使用目的和正確的操作規定進行安裝。任何時刻，都應遵守製造商的維護和維修指南，如有疑問請諮詢製造廠技術部門。

· 對於使用R290製冷劑的抽濕機的安裝適用以下檢查專案：

- 充注量應根據裝有含製冷劑部件房間的大小來確定。
- 通風設備應正常運行，且通風口應無阻礙。
- 如果使用間接的製冷迴圈，則應檢查二級回路中是否有製冷劑的存在。
- 抽濕機上的標識應清晰可見，應更正模糊不清的標記和符號。
- 製冷管路或電氣元件不應安裝在含有可能腐蝕接觸製冷劑元件的環境中，除非電氣元件本身是由抗腐蝕的材料製成或採取合適的防腐措施。

· 電氣裝置的檢查

· 電氣元件的維修和維護應包括初始的安全檢查和元件檢查步驟。如果存在危及安全的缺陷，則要將器具電源斷電，直到缺陷得到妥善的處置。如果最後不能完全消除缺陷，而且又必須繼續操作，那麼就應當採取適當的臨時解決方法。將此情況報告給器具的所有者，並且對所有人員提出警告。

· 初始的安全檢查應當包括：

- 電容放電，應以安全的方式進行，以避免產生電火花。
- 在充注、回收和清洗系統的過程中沒有裸露在外的電氣元件和配件。
- 接地的連續性。

· 密封元件的維修

· 維修封閉元件時，在打開密封的蓋子之前應先斷開設備的供電電源。如果在維修過程中必須有電力供給，應對最危險的部分進行不間斷的洩漏檢測，以防止潛在的危險情況出現。

· 對電氣元件的上述維修中應特別注意不要發生影響外殼防護等級的維修方式。不當的維修方式可能導致：線纜受損、過量連接、端子未按原來的規定安裝、密封受損、密封蓋安裝錯誤等危險。確保設備的安裝安全可靠。確保密封或密封材料不會由於老化而喪失防止可燃性氣體進入的作用。替代部件應當符合製造商的規範要求。

· 備註：使用含矽的密封劑可能會減弱檢漏設備的檢測能力。本質安全型元件在操作前不必隔離。

· 本質安全型元件的維修

- 若不能確保器具在使用過程中不超過允許電壓和電流的限定時，不得在電路中使用任何永久性的感電或電容負載。
- 本質安全型元件是唯一可以在可燃性氣體內繼續工作的元件。測試儀器要設定在正確的檔位上。
- 若更換元件只能採用製造商指定的零部件，其他零部件可能會導致洩漏在空氣中的製冷劑著火。

· 線纜

檢查線纜是否會受到磨損、腐蝕、過壓、震動、鋒利邊緣或其他不利環境的影響。該檢查也應考慮老化或壓縮機、風扇的持續震動對線纜造成的影響。

· R290製冷劑的檢查

檢查製冷劑的洩漏應當在沒有潛在點火源的環境中進行。不應使用鹵素探頭（或其他任何使用明火的探測器）進行檢測。

· 洩漏檢測方法

對於含有R290製冷劑的系統，以下檢測洩漏的方法是接受的：

- 電子檢漏儀可用於R290製冷劑的檢測，但是靈敏度可能達不到要求，或是可能需要重新校準（儀器的校準應在不含製冷劑的環境中進行）。確保檢漏儀不會成為潛在的點火源，並且適用於所測的製冷劑。檢漏儀應設定為製冷劑的最低可燃濃度（以百分數表示），用所使用的製冷劑標定並調節到適當的氣體濃度測試量程（最高25%）。
- 檢測洩漏所用的流體適用於大多數製冷劑，但是不要使用含氣的溶劑，以防止氣和製冷劑發生反應以及腐蝕銅質的管路。
- 如果懷疑有洩漏，則應將所有的明火從現場移走或將火熄滅。
- 如果發生洩漏的位置需要進行焊接，則應回收所有製冷劑，或將製冷劑全部隔離（使用截止閥門）在遠離洩漏點的部位。在進行焊接之前以及在焊接的過程中，要使用無氧氮（OFN）對整個系統進行淨化。

· 移除和抽真空

· 對製冷回路進行維修或其他作業時應按常規程式操作，但也應重點考慮製冷劑的可燃性，按照以下程式操作：

1. 清除製冷劑。
2. 用惰性氣體淨化管路。

3. 抽真空。

4. 再次用惰性氣體淨化管路。

5. 切割管路或進行焊接。

- 製冷劑應回收到合適的儲罐中，系統應用無氧氮進行吹洗以確保安全。這一過程可能需要重複幾次。此作業不得使用壓縮空氣或氧氣進行。
- 洗過程在系統真空狀態下向系統內充如無氧氮達到工作壓力，然後將無氧氮排放到大氣中，最後再將系統抽成真空。重複此過程直至系統中的製冷劑全部清除。最後一次充入無氧氮後，排放氣體至大氣壓力，然後系統可以進行焊接。如進行管路焊接作業，上述操作是很有必要的。
- 確保真空泵的出口附近沒有任何點燃的火源並且通風良好。

· 充注製冷劑過程

作為對常規程式的補充，增加以下要求：

- 確保在使用製冷劑充注設備時，不會發生不同製冷劑之間的相互污染。充注製冷劑的管路應當盡可能短，以減少製冷劑在其內的殘餘量。
- 儲罐要保持垂直向上。
- 確保製冷系統在充注製冷劑前已採取接地措施。
- 充注完成後（或尚未完成時）在系統上貼上標籤。
- 必須注意不可過量充注。
- 在向系統再次充注之前用無氧氮進行壓力測試。充注完成後要在試運行之前進行洩漏測試。在離開該區域時應再進行一次洩漏測試。

· 報廢

在進行此程式前，技術人員應該對設備及其所有的特性都已完全熟悉。推薦實施安全回收製冷劑的做法。如需對回收的製冷劑進行再次利用，進行作業之前，應對製冷劑和油的樣本進行分析。測試之前應保證得到所需的電源。

- 熟悉設備和操作。
- 斷開電源。
- 在進行此程式前確保：
 - 如需要，機械操作設備應便於對製冷劑儲罐進行操作。
 - 所有的人身保護器具是有效的，並且能被正確使用。
 - 整個回收過程要在有資格的人員指導下進行。
 - 回收設備和儲罐應符合相應的標準。
- 如可能，應對製冷系統抽真空。
- 如達不到真空狀態，應從多處進行抽取，以抽出系統各部分中的製冷劑。
- 在開始回收之前應確保儲罐的容量足夠。
- 按照製造商的操作說明啟動和操作回收設備。
- 不要將儲罐裝得過滿（液體注入量不超過80%的儲罐容積）。
- 即使是持續短時間，也不得超過儲罐的最大工作壓力。
- 在儲罐裝完成以及作業過程結束後，要確保將儲罐和設備迅速移走，並且設備上所有截止閥均已關閉。
- 回收的製冷劑在經過淨化和檢驗前不得注入另一種製冷系統。

· 標識

器具在報廢並且排空製冷劑後應標識，標識應有日期和簽注。確保器具上的標識能反映出此器具所容納的R290製冷劑。

· 回收

- 維修或報廢處理時需清除系統中的製冷劑，建議最好是徹底清除製冷劑。
- 把製冷劑裝入到儲罐時，只能使用專業的製冷劑儲罐。需確保儲罐的容量與整個系統中的製冷劑注入量相適應。所有都是打算用於回收製冷劑的儲罐並且以該製冷劑標識（即製冷劑專用回收儲罐）。儲罐應配有卸壓閥和截止閥並且處於良好狀態。如果可能，儲罐在使用前應抽真空並保持常溫狀態。
- 回收設備應當保持良好工作狀態，並且有設備操作說明用於查閱，設備應適用於R290製冷劑的回收。另外，還要有計量合格能夠正常使用的稱重儀器。軟管應當使用無洩漏型可拆接頭連接，並且保持良好的狀態。在使用回收設備前應檢查其是否處於良好狀態，是否得到完善的保養，所有電氣部件都已密封以防一旦製冷劑洩漏導致火災，如有疑問請諮詢製造商。
- 回收的製冷劑應當裝在適用的儲罐中，並附上運輸說明，返回製冷劑製造商。不要在回收設備尤其是儲罐中混合製冷劑。
- 若拆除壓縮機或清除壓縮機油時，要確保壓縮機抽真空至適宜的水準以確保潤滑油中沒有殘留的R290製冷劑。抽真空在壓縮機返回供應商之前進行。只允許使用電加熱方式加熱壓縮機殼體以加快此過程。當油從系統中排出時，應當確保安全。

聲明

隨著產品的技術更新，與本產品相同型號的產品使用說明書內容可能會有所變更，更新部分恕不另行通知。

本說明書中展示的所有圖示僅用作示例說明用途，實際外觀請以所購買的產品為準。

由於產品不斷升級，部分參數可能有所變更，變更後的參數恕不另行通知，請以本產品銘牌參數為準。

本說明書相關條款解釋權歸威諾威環境有限公司所有。

說明書版本號：V1.0

Safety Instructions



This symbol shows that this appliance uses a highly flammable refrigerant. If the refrigerant is leaked and exposed to an external ignition source, there is a risk of fire.

Caution: Risk of fire



Read this manual carefully before use and maintenance, and retain it for future reference.



This symbol shows that information is available in the user manual.



This symbol shows that the service personnel should be handling this equipment with reference to the user manual.

To prevent injury to the user or other people and property damage, the following instructions must be followed. Incorrect operation due to ignoring instructions may cause harm or damage.

- The seriousness is classified by the following indications.

 **WARNINGS** This symbol indicates the possibility of death or serious injury.

 **CAUTIONS** This symbol indicates the possibility of injury or damage to property.

- Meanings of symbols used in this manual are as shown below.

 This symbol indicates forbidden actions.

 This symbol indicates actions that should be followed.

CAUTIONS

- This appliance can be used by children aged from 8 years and above and persons with reduced physical, sensory or mental capabilities or lack of experience and knowledge if they have been given supervision or instruction concerning use of the appliance in a safe way and understand the hazards involved. Children shall not play with the appliance. Cleaning and user maintenance shall not be made by children without supervision.
- This appliance is not intended for use by persons (including children) with reduced physical, sensory or mental capabilities, or lack of experience and knowledge, unless they have been given supervision or instruction concerning use of the appliance by a person responsible for their safety.
- Failure to strictly follow the precautions may cause serious accidents such as personal injury or death.
- Children should be supervised to ensure that they do not play with the appliance.
- If the supply cord is damaged, it must be replaced by the manufacturer, its service agent or similarly qualified persons in order to avoid a hazard.
- Before cleaning the dehumidifier, stop it from running and turn it off.

- To prevent fire, explosion or injury, do not use the dehumidifier where there may be flammable or corrosive gases nearby.
 - Do not place the dehumidifier near a heat source to avoid the deformation of the dehumidifier or fire.
 - Do not repair, disassemble, modify or clean the internal components by yourself, as improper handling may cause water leakage, electric shocks, or fire. When repairs are needed, contact the after-sales service team.
 - Do not poke fingers, sticks, or any other object into the air inlet or the air outlet. Otherwise, it may result in product failure or damage, or even personal injury.
 - Do not operate the dehumidifier, or plug in or unplug the power cord with wet hands to prevent electric shocks.
 - Do not clean the dehumidifier directly with water or use the dehumidifier in places where it may come into contact with water to avoid electric shock or fire.
 - Do not place containers of water, such as vases, on top of the dehumidifier, as this may result in electric shock or fire.
 - Unplug the dehumidifier to turn it off before care and maintenance to avoid electric shock or fire.
 - This appliance contains only functional grounding connections.
 - Do not exceed the rating of the electrical outlet or connection device. Otherwise, it may cause electric shock or fire due to excess heat generation.
 - Do not modify power cord length or share the electrical outlet with other appliances. It may cause electric shock or fire due to heat generation.
 - Do not drink or use the water drained from the dehumidifier. It contains contaminants and could make you sick.
 - Do not take the water tank out during operation as the contact switch on the tank will not disconnect the dehumidifier from power and there is a risk of electric shock.
- ⚠ If you notice anything unusual (e.g, smell of burning), you should immediately unplug the dehumidifier and contact the after-sales service team for a solution. Continued use in such circumstances may result in damage, electric shock, or fire.

⚠ WARNINGS

- Do not use means to accelerate the defrosting process or to clean, other than those recommended by the manufacturer.
- The appliance shall be stored in a room without continuously operating ignition sources, for example open flames, an operating gas appliance or an operating electric heater.
- Do not pierce or burn.
- Be aware that refrigerants contain an odour.
- Appliance shall be installed, operated and stored in a room with a floor area larger than 4 m².

- The installation space of refrigerant pipeline should comply with national gas regulations.
- Keep ventilation openings clear of obstruction.
- The appliance shall be stored to prevent mechanical damage from occurring.
- Any person who is involved with working on or repairing refrigerating circuits should possess a valid certificate issued by industry-recognized assessment organizations/manufacturer/agent certifying that they have the necessary qualifications required for handling refrigerants safely.
- Only maintain and repair the dehumidifier following the methods recommended by the manufacturer. If other technicians are required for assistance, the maintenance or repair should be supervised by persons qualified for handling R290 refrigerants.
- The appliance shall be stored in a well-ventilated area where the room size corresponds to the room area as specified for operation.
- All working procedures that affect safety means shall only be carried by competent persons.

⚠ CAUTIONS

Failure to strictly follow the precautions may result in personal injury or damage to property.

- ⊘ Do not climb or sit on the dehumidifier to prevent it from becoming deformed.
- Do not allow the dehumidifier to blow directly onto plants or animals to avoid adverse effects.
- Do not place objects with open flames by the outlet of the dehumidifier. Otherwise, toxic gases may be generated due to incomplete combustion.
- Do not block the air inlet or the air outlet of the dehumidifier. Otherwise, the dehumidifier's performance may be reduced or malfunction.
- When the dehumidifier is not used for a long period of time, disconnect it from the electrical outlet and empty the water tank. Dry the water tank thoroughly and reinstall it back into the dehumidifier. Then leave the dehumidifier for two days and put it away.
- The compressor inside the dehumidifier must be kept upright. If the dehumidifier has been tipped over or transported for a long distance, stand it upright for at least 4 hours before turning it on.
- Do not use the dehumidifier in small spaces. Lack of ventilation can cause overheating and fire.
- Do not use the dehumidifier in areas where chemicals are handled. This will cause the deterioration of dehumidifier due to chemicals and solvents dissolved in the air.
- Do not place heavy object on the power cord and make sure that the cord is not compressed to avoid the danger of fire or electric shock.

- ❗ • Do not use the dehumidifier in a laundry room.
- If the temperature around the hose falls below zero, do not use the function of continuous drainage.
- Do not drag the dehumidifier across a carpet to prevent it from being toppled over.
- Place the dehumidifier on a stable, level surface. Otherwise, its performance may be reduced.
- Clean the dehumidifier's air filter regularly, as the performance of the dehumidifier may be reduced if the filter is dirty or blocked.
- Do not place the dehumidifier against objects or walls. Make sure there must be at least 20 cm of clearance around the dehumidifier and at least 50 cm above its air outlet.
- For optimal performance, the dehumidifier should be operated in enclosed spaces. Close doors and windows, and turn off other ventilating devices when using the dehumidifier.
- If water enters the dehumidifier, turn the dehumidifier off by disconnecting it from power, and then contact a qualified service technician. Otherwise, it may cause a failure of the dehumidifier or an accident.
- The dehumidifier shall be installed in accordance with national wiring regulations.
- The appliance with electric heater shall have at least 1 meter space to the combustible materials.
- Contact the authorized service technician for repair or maintenance of this dehumidifier.
- Do not use the electrical outlet if it is loose or damaged.
- Do not use this dehumidifier for functions other than those described in this user manual.
- Contact the authorized installer for installation of this dehumidifier.
- In a thunderstorm, the power must be cut off to avoid damage to the dehumidifier due to lightning.
- Do not run the power cord under carpeting. Do not cover the cord with throw rugs, runners, or similar coverings. Do not route the cord under furniture or appliances. Arrange the cord away from traffic areas and where it will not be tripped over.
- Do not open the dehumidifier during operation.
- When the filter is to be removed, do not touch the metal parts of the dehumidifier.
- Hold the power plug when unplugging the power cord.

Electrical information

- The manufacturer's nameplate is located on the rear panel of the dehumidifier and contains electrical and other technical data specific to this dehumidifier.
- Be sure the dehumidifier is properly grounded. To minimize the electric shock and fire hazards, proper grounding is important. The power cord is equipped with a three-pronged grounding plug for protection against electric shock hazards.
- The dehumidifier must be used in a properly grounded wall socket. If the wall socket you intend to use is not adequately grounded or protected by a time-delay fuse or circuit breaker, it may cause electric shock and fire. The time-delay fuse or circuit breaker needed is determined by the maximum current of the dehumidifier, and the maximum current is indicated on the nameplate located on the dehumidifier. Make sure to have a qualified electrician install the proper socket.
- Ensure the electrical outlet is accessible after the installation of the dehumidifier.
- Do not use extension cords or power adapters with this dehumidifier. However, if it is necessary to use an extension cord, use only approved extension cords for dehumidifiers (available at most local hardware stores).
- To avoid the possibility of personal injury, always disconnect the dehumidifier from power before installing and/or servicing.
- All wiring must be performed strictly in accordance with the wiring diagram located on the electrical box of the dehumidifier.

Fuse specifications

The dehumidifier's circuit board (PCB) is designed with a fuse to provide overcurrent protection. The specifications of the fuse are printed on the circuit board, such as: T 3.15 A/250 V (or 350 V), etc.

Note about hydrocarbon:

- Hydrocarbon are contained in hermetically sealed equipment. For specific information on the type, the amount and the CO₂ equivalent in tonnes of the hydrocarbon used in the refrigerant of this dehumidifier, refer to the relevant label on the dehumidifier.
- Installation, service, maintenance and repair of this dehumidifier must be performed by a certified technician.
- The disassembling and recycling of the dehumidifier must be performed by a certified technician.

Product Overview

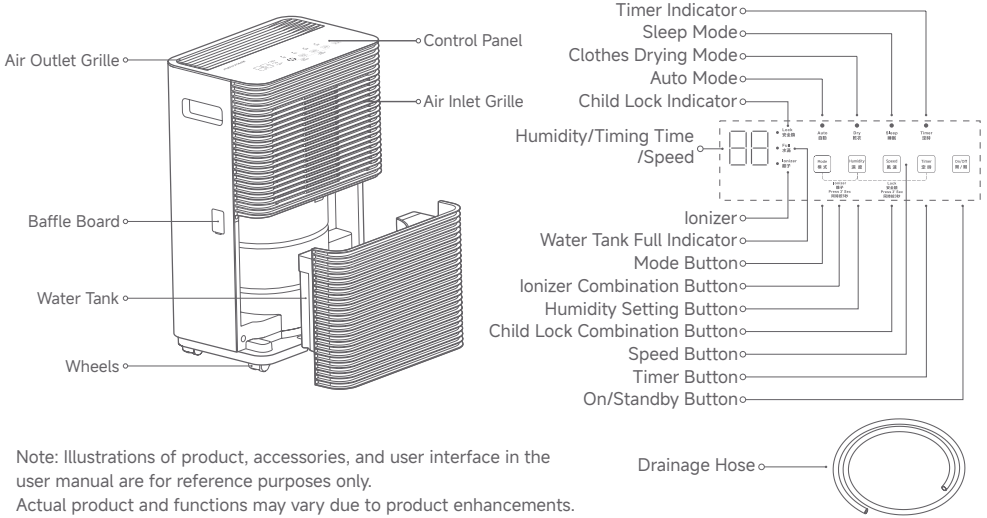



Note: Illustrations of product, accessories, and user interface in the user manual are for reference purposes only. Actual product and functions may vary due to product enhancements.

How to Use

Turning on

Plug the dehumidifier and press the button  to turn it on.

Standing by

- When the dehumidifier is turned on, press the button  to enter standby mode.
- The dehumidifier will dry for 40 minutes before entering standby mode to reduce moisture inside. During drying, you can press the button  to forcibly enter standby mode.

Turning off

Unplug the dehumidifier to turn it off.

Switching modes

When the dehumidifier is on, press the button  to cycle through the modes of auto, clothes drying, and sleep.

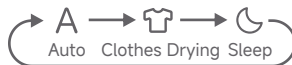

- Auto mode: The dehumidifier will automatically adjust its settings and fan speed to the room's humidity level and the expected humidity that you set.
- Clothes drying mode: The dehumidifier will run at a high speed and deliver powerful dehumidifying performance, and the humidity cannot be set manually in this mode. For optimal drying effect, it is recommended to spin-dry the clothes first and then continue to dry clothes in an enclosed room.
- Sleep mode: The dehumidifier will start and stop automatically based on the room's humidity level and the expected humidity that you set.

Notes:

- In Auto mode, the target humidity and Speed can be set by yourself. If set by yourself, the auto indicator will be turned off and enter the custom setting state.
- In sleep mode, the dehumidifier will make a normal operating sound. To avoid disturbing your rest, it is recommended to keep the dehumidifier away from your bed, make it enter standby mode, or disconnect it from power before bedtime.
- The dehumidifier makes low noise during operation, so there is no significant difference in noise levels between different modes, which is normal.

- In sleep mode, the dehumidifier will make a normal operating sound. To avoid disturbing your rest, it is recommended to keep the dehumidifier away from your bed, make it enter standby mode, or disconnect it from power before bedtime.



Setting the expected humidity

When the dehumidifier is on, press the button  to cycle through the expected humidity: 40%, 45%, 50%, 55%, 60%, 65%, and 70%.

Setting the speed

Press the button  to cycle through the speed: AU (Auto) → F1 (Low Speed) → F2 (High Speed)

Scheduling standby time

- When the dehumidifier is on, press the button  to schedule your standby time. The scheduled standby time can be increased by 1 hour and the settable range is 1–12 hours.
- If the desired standby time is selected with no operation for 5 seconds, the setting will take effect automatically and the icon  will appear on the display.

Note: The dehumidifier will dry for 40 minutes before entering standby mode.

Enabling/Disabling the child lock function

Press and hold the buttons  and  simultaneously for 3 seconds to enable or disable the child lock function.

When the function is enabled, the display will show the icon  and the dehumidifier will not respond to button operations.

Water tank full alert

When the dehumidifier is operating, if the water tank gets too full or is installed improperly, the dehumidifier will beep 5 times as an alert, and the water full indicator  on the display will blink continuously.

All buttons except for button  cannot function.

Once the water level in the tank returns to normal and the water tank is secured properly in place, the indicator  will go out and the dehumidifier will resume normal operation.

Note: Once the water full alert occurs, pour out some water from the water tank and reinstall the water tank properly.

Defrosting

When the dehumidifier is operating, it will automatically defrost if its evaporator and condenser are covered by frost. The compressor will stop operating and the fan will continue to run until defrosting is complete.

During defrosting, the icon  will blink slowly on the display. Once the defrosting is complete, the icon of the mode that was running before defrosting will light on, and the dehumidifier will resume normal operation.

Continuous drainage

1. Pull the water tank out horizontally from the opening at the bottom of the water tank.
2. Open the baffle board on the rear shell.
3. Connect the drainage hose to the water outlet.
4. Reinstall the water tank and connect the other end of the drainage hose to the drainage. Then the dehumidifier can drain water automatically.

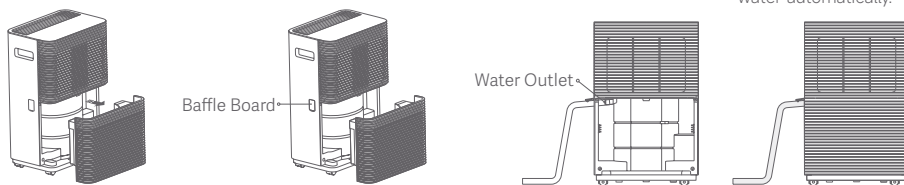

Note: When draining off water, make sure the end of the drainage hose is lower than the dehumidifier's water outlet, and the hose hangs down smoothly without being wavy and is not overly bent.

Care & Maintenance

⚠ Maintenance precautions

- Before cleaning, make sure to disconnect the dehumidifier from power to avoid electric shocks.
- Do not rinse or submerge the dehumidifier in liquid. Do not drip any water into the dehumidifier.
- Do not use any volatile liquids (e.g., thinner and gasoline) to wipe the dehumidifier to avoid damaging its appearance. Use a wet cloth with neutral detergent to clean the dehumidifier's shell, then use a soft dry cloth to wipe again.
- Clean the filter regularly to avoid the dehumidifier's performance being reduced by the buildup of dust. If the dehumidifier is used in a dusty environment, cleaning should be carried out more frequently. After removing the filter, do not touch the finned parts inside the dehumidifier with your fingers to avoid cutting yourself.

Cleaning the dehumidifier

Soak a cloth in water below 45°C, then wring it out and use it to gently wipe over the dirty area.

Cleaning the filter

1. Pull the water tank out horizontally from the opening at the bottom of the water tank, and then pull the filter downwards from the bottom of the air inlet grille.

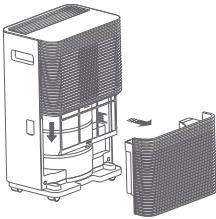

2. Rinse the filter and the air inlet grille with water or use a vacuum cleaner to clean them. If the filter is particularly dirty (such as with oil stains), you should use warm water (below 45°C) with neutral detergent to clean it, and then dry it in a cool place.

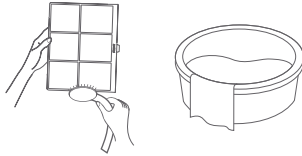

3. Reinstall the filter and the water tank in order.

Note: Install the filter in the direction as illustrated.

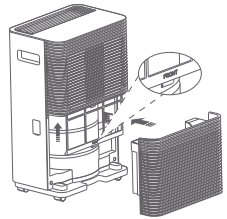

Cleaning the water tank

1. Pull the water tank out horizontally from the opening at the bottom of the water tank.
2. Remove the cover of the water tank from the spout.

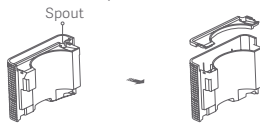

3. Clean the water tank and fully dry it. Then attach the cover to the water tank, and reinstall the water tank.

Long-term storage

1. Let the dehumidifier sit for two days after making it enter standby mode and unplugging it.
2. Clean the dehumidifier, the water tank, and the filter.
3. Coil up the power cord and secure it with a cable tie.
4. It is recommended to store the dehumidifier in packaging.
5. Store the dehumidifier upright in a dry and well-ventilated place.

Troubleshooting

Issue	Cause and Solution
The dehumidifier suddenly shakes when it turns on, enters standby mode, or operates.	<ul style="list-style-type: none">• This is caused by the start or stop of the compressor, which is normal.
The dehumidifier does not work well.	<ul style="list-style-type: none">• It is recommended to use the dehumidifier indoors at a temperature from 5°C to 35°C.• Check whether the humidity is set appropriately.• Check whether the air inlet or the air outlet is dirty or blocked, and clean them in time.• Check whether the doors and windows are open. It is recommended to close the doors and windows and turn off other ventilation equipment when the dehumidifier is operating.
The dehumidifier cannot work.	<ul style="list-style-type: none">• Check whether there is a power failure.• Check whether the power plug has become loose.• Check whether the water tank is full or has been installed incorrectly.• Check whether the timer function is being used.
The dehumidifier leaks water.	<ul style="list-style-type: none">• Check whether the drainage hose has become loose.• Check whether the drainage system is blocked.
The dehumidifier makes unusual sounds when running.	<ul style="list-style-type: none">• Check whether the dehumidifier is on a flat surface.• Check whether the filter is blocked.• Check whether the refrigerant makes sound when the compressor is turned on.
Black stains appear in the water tank.	<ul style="list-style-type: none">• The black stains are caused by the air dust and the materials attached to the surfaces of the evaporator and condenser. They flow into the water tank with the condensate water. This is normal.• Directly wipe them with a paper towel. The black stains will decrease with continued use.

Common Error Codes

Code	Description	Solution
C2	Fan error	Turn the dehumidifier off for 5 minutes and then turn it on again. If the error code appears multiple times, please contact the after-sales service team for help.
C3	Communication error between display and motherboard	Disconnect the dehumidifier from the electrical outlet then reconnect it to the electrical outlet. If the issue persists, please contact the after-sales service team for help.
E1	Pipe temperature sensor error	Turn the dehumidifier off for 5 minutes and then turn it on again. If the error code appears multiple times, please contact the after-sales service team for help.
E9	Humidity sensor error	Turn the dehumidifier off for 5 minutes and then turn it on again. If the error code appears multiple times, please contact the after-sales service team for help.
H2	Overload protection	Check whether the dehumidifier's air inlet or air outlet is blocked. Turn the dehumidifier on again, and if the error code appears multiple times, please contact the after-sales service team for help.
H6	Fluoride deficiency protection	Turn the dehumidifier off for 5 minutes and then turn it on again. If the error code appears multiple times, please contact the after-sales service team for help.
H8	Overheating protection	Make sure the dehumidifier is working between 5°C and 35°C. If the error code still appears, please contact the after-sales service team for help.

Note: The error code will appear on the dehumidifier's display.

Specifications

- The dehumidifier's capacity is measured at the calibrated ambient temperature and humidity. The results may vary due to the actual operating conditions.
- The dehumidifier's operating temperature range is from 5°C to 35°C. If the indoor temperature is out of this range, the dehumidifier may not be able to work.
- If the specifications change, the details on the dehumidifier's nameplate shall prevail without notice.

Name: Gemini Dehumidifier	Model: GDW13W
Rated Voltage: 220–240 V-	Noise: ≤38 dB(A)
Rated Frequency: 50 Hz	Net Weight: 10.8 kg
Refrigerant: R290/0.046 kg	Air Flow Rate: 125 m ³ /h
Rated Power Input: 185 W	Water Tank Capacity: 1.8 L
Maximum Input Current: 1.30 A	Item Dimensions: 290 × 455 × 195mm
Power Input: 145 W (26.7°C/60% RH)	Operating Temperature: 5°C to 35°C
165 W (30°C/80% RH)	Fuse: T3.15 A/250 V
Dehumidification Capacity: 7 L/D (26.7°C/60% RH)	Power Cord: 3 × 0.75 mm ²
13.5 L/D (30°C/80% RH)	

Warning: Install, operate, and store the dehumidifier in a room larger than 4 m².

Safety Precautions on Servicing

WARNINGS

- To repair or dispose of the dehumidifier, contact the after-sales service team.
- This dehumidifier uses refrigerant R290, and it must be repaired by professionals.
- Transport of equipment containing flammable refrigerants
See transport regulations.
- Marking of equipment using signs
See local regulations.
- Disposal of equipment using flammable refrigerants
See national regulations.
- Storage of equipment/appliances
The storage of equipment should be in accordance with the manufacturer's instructions.
- Storage of packed (unsold) equipment
 - Storage package protection should be constructed such that mechanical damage to the equipment inside the package will not cause a leak of the refrigerant charge.
 - The maximum number of pieces of equipment permitted to be stored together will be determined by local regulations.
 - To realize the function of the dehumidifier, a special refrigerant circulates in the system. The used refrigerant is R290 (propane), which is highly flammable.
 - The refrigerant is flammable and inodorous. Furthermore, it can lead to explosion under certain conditions.
 - Compared to common refrigerants, R290 is a nonpolluting refrigerant with no harm to the ozoneosphere. The influence upon the greenhouse effect is also lower. R290 has got very good thermodynamic features which lead to a really high energy efficiency. The units therefore need less filling.
- Qualification of Service Personnel
 - Any person who is involved with working on or repairing refrigerating circuits should possess a valid certificate issued by industry-recognized assessment organizations/manufacturer/agent certifying that they have the necessary qualifications required for handling refrigerants safely.
 - Only maintain and repair the dehumidifier following the methods recommended by the manufacturer. If other technicians are required for assistance, the maintenance or repair should be supervised by persons qualified for handling R290 refrigerants.

- Checks to the Area:

Prior to beginning work on the dehumidifier that uses refrigerant R290, safety checks are necessary to ensure that the risk of ignition is minimized. For repair to the refrigerating system, the following precautions shall be complied with before conducting work on the system.

- Work procedure:

Work shall be undertaken under a controlled procedure to minimize the risk of flammable gas or vapor being present while the work is being performed.

- General work area:

All maintenance staff and others working in the local area shall be instructed on the nature of the work being carried out. Work in confined spaces shall be avoided. To ensure safety, the area around the operating space shall be sectioned off and combustible materials should be controlled.

- Check for the presence of refrigerant:

The area shall be checked with an appropriate refrigerant detector prior to and during work, to ensure the technician is aware of potentially flammable atmospheres. Ensure that the leak detection equipment being used is suitable for use with flammable refrigerants, i.e. non-sparking, adequately sealed, or intrinsically safe.

- Presence of fire extinguisher:

If any hot work is to be conducted on the refrigerating equipment or any associated parts, appropriate fire extinguishing equipment shall be available to hand. Have a dry powder or CO₂ fire extinguisher adjacent to the charging area.

- No ignition sources:

No person carrying out work in relation to a refrigerating system that involves exposing any pipe work that contains or has previously contained flammable refrigerants shall use any sources of ignition in such a manner that it can lead to the risk of fire or explosion. All possible ignition sources, including cigarette smoking, should be kept sufficiently far away from the site of installation, repair, removal, and disposal, during which refrigerant can be released into the surrounding space. Prior to work taking place, the area around the equipment is to be surveyed to make sure that there are no flammable hazards or ignition risks. "No Smoking" signs shall be displayed.

- Ventilated Area

Ensure that the area is in the open or that it is adequately ventilated before breaking into the system or conducting any hot work. A degree of ventilation shall continue during the period that the work is carried out. The ventilation should safely disperse any released refrigerant and preferably expel it externally into the atmosphere.

- Checks to the Refrigerating Equipment

- Where electrical components are being changed, they shall be fit for the purpose and to the correct specification. At all times the manufacturer's maintenance and service guidelines shall be followed. If in doubt, consult the manufacturer's technical department for assistance.

- The following checks shall be applied to installations of dehumidifiers using R290 refrigerants:

- The refrigerant charge is in accordance with the room size within which the refrigerant-containing parts are installed.
- The ventilation machinery and outlets are operating adequately and are not obstructed.
- If an indirect refrigerating circuit is being used, the secondary circuit shall be checked for the presence of refrigerant.
- Marking to the dehumidifier continues to be visible and legible. Markings and signs that are illegible shall be corrected.
- Refrigerating pipe or electrical components are installed in a position where they are unlikely to be exposed to any substance that can corrode refrigerant-containing components, unless the electrical components are constructed of materials that are inherently resistant to being corroded or are suitably protected against being so corroded.

- Checks to Electrical Devices

- Repair and maintenance of electrical components shall include initial safety checks and component inspection procedures. If a fault exists that could compromise safety, then no electrical supply shall be connected to the circuit until it is satisfactorily dealt with. If the fault cannot be corrected completely in the end, but it is necessary to continue operation, an adequate temporary solution shall be used. This shall be reported to the owner of the equipment so all parties are advised.

- Initial safety checks shall include:

- That capacitors are discharged: this shall be done in a safe manner to avoid the possibility of sparking.
- That no live electrical components and accessories are exposed while charging, recovering, or purging the system.
- That there is continuity of earth bonding.

- Repairs to Sealed Components

- To repair sealed components, disconnect the dehumidifier from power before opening any sealed cover. If electrical power must be supplied during repair, continuous leak detection shall be performed on the most dangerous parts to prevent potential dangers.

- Do not affect the protection level of the casing when repairing electrical components. Improper repair methods may lead to dangers such as damaged cables, excessive number of connections, terminals not installed as originally specified, damaged seals, and seal covers improperly installed. Ensure that the dehumidifier is installed safely, and that the seals or sealing materials have not lost their capability to prevent flammable gases from entering due to aging. Replacement parts shall meet the manufacturer's specifications.

- Note: Silicon-containing sealants may affect the performance of leak detection equipment. There is no need to isolate intrinsically safe components before operation.
- Repairs to Intrinsically Safe Components
 - If it cannot be ensured that the dehumidifier will not exceed the permissible voltage and current limits during use, do not use any permanent inductive or capacitive load in the electrical circuit.
 - Intrinsically safe components are the only ones that can continue to function in flammable gases. Ensure that the test instrument is configured to the correct setting.
 - Only use the parts specified by the manufacturer for replacement, as other parts may ignite the refrigerant leaked into the air.
- Cabling

Check that cabling will not be subject to wear, corrosion, excessive pressure, vibration, sharp edges, or any other adverse environmental effects. The check shall also take into account the effects of aging or continual vibration from sources such as compressors or fans.
- Detection of Refrigerant R290

Under no circumstances shall potential sources of ignition be used in the search for or detection of refrigerant leaks. A halide torch (or any other detector using a naked flame) shall not be used.
- Leak Detection Methods

The following leak detection methods are deemed acceptable for systems containing refrigerant R290:

 - Electronic leak detectors may be used to detect refrigerant R290, but the sensitivity may be inadequate or may need re-calibration (Detection equipment shall be calibrated in a refrigerant-free area). Ensure that the detector is not a potential source of ignition and is suitable for the refrigerant used. Leak detection equipment shall be set at a percentage of the lower flammability limit (LFL) of the refrigerant and shall be calibrated to the refrigerant employed, and the appropriate percentage of gas (25% maximum) is confirmed.
 - Leak detection fluids shall be suitable for use with most refrigerants but the use of solvents containing chlorine shall be avoided as the chlorine can react with the refrigerant and corrode the copper pipe-work.
 - If a leak is suspected, all naked flames shall be removed or extinguished.
 - If a leakage of refrigerant is found which requires brazing, all of the refrigerant shall be recovered from the system, or isolated by means of shut-off valves in a part of the system remote from the leak. Before and during brazing, purge the entire system with oxygen-free nitrogen (OFN).
- Removal and Evacuation
 - When breaking into the refrigerant circuit to make repairs or for any other purpose, conventional procedures shall be used. However, special attention shall also be given to the flammability of the refrigerant. The following procedure shall be adhered to:
 1. Remove the refrigerant.
 2. Purge the circuit with inert gas.
 3. Evacuate.
 4. Purge the circuit again with inert gas.
 5. Cut or braze the circuit.
 - The refrigerant charge shall be recovered into the correct recovery cylinders. Oxygen-free nitrogen shall be used to purge the system to ensure safety. It may be necessary to repeat this process multiple times. Compressed air or oxygen shall not be used for purging refrigerant systems.
 - Purging of the refrigerant circuit shall be achieved by breaking the vacuum in the system with oxygen-free nitrogen and continuing to fill until the working pressure is achieved, then venting to the atmosphere, and finally pulling down to a vacuum. This process shall be repeated until no refrigerant is within the system. The system shall be vented down to atmospheric pressure after the final filling of oxygen-free nitrogen, and then the system can be brazed. If brazing operations are needed, it is necessary to perform the above process.
 - Ensure that the outlet of the vacuum pump is not close to any potential ignition sources and that ventilation is available.
- Refrigerant Charging Procedures

In addition to conventional charging procedures, the following requirements shall be followed:

 - Ensure that contamination of different refrigerants does not occur when using charging equipment. Hoses or lines shall be as short as possible to minimize the amount of refrigerant contained in them.
 - Cylinders shall be kept upright.
 - Ensure that the refrigerating system is earthed before charging the system with refrigerant.
 - Label the system after or before the completion of charging.
 - Extreme care shall be taken not to overfill the refrigerating system.
 - Prior to recharging the system, it shall be pressure-tested with oxygen-free nitrogen. The system shall be leak-tested on completion of charging but prior to commissioning. A follow-up leak test shall be carried out prior to leaving the site.
- Commissioning

Before carrying out this procedure, it is essential that the technician is completely familiar with the equipment and all its details. It is recommended good practice that all refrigerants are recovered safely. Prior to the task being carried out, an oil and refrigerant sample shall be taken in case analysis is required prior to re-use of recovered refrigerant. It is essential that

electrical power is available before the task is commenced.

- Become familiar with the equipment and its operation.
- Isolate system electrically.
- Before attempting the procedure, ensure that:
 - mechanical handling equipment is available, if required, for handling refrigerant cylinders;
 - all personal protective equipment is available and being used correctly;
 - the recovery process is supervised at all times by a competent person;
 - recovery equipment and cylinders conform to the appropriate standards.
- Pump down the refrigerant system, if possible.
- If a vacuum is not possible, make a manifold so that refrigerant can be removed from various parts of the system.
- Make sure that the cylinder has sufficient capacity before recovery takes place.
- Start the recovery machine and operate in accordance with instructions.
- Do not overfill cylinders (no more than 80% volume liquid charge).
- Do not exceed the maximum working pressure of the cylinder, even temporarily.
- When the cylinders have been filled correctly and the process completed, make sure that the cylinders and the equipment are removed from the site promptly and all isolation valves on the equipment are closed off.
- Recovered refrigerant shall not be charged into another refrigerating system unless it has been cleaned and checked.
- Labeling
Equipment shall be labeled stating that it has been de-commissioned and emptied of refrigerant. The label shall be dated and signed. Ensure that there are labels on the equipment stating the equipment contains refrigerant R290.
- Recovery
 - When removing refrigerant from a system, either for servicing or decommissioning, it is required to follow good practice so that all refrigerants are removed safely.
 - When transferring refrigerant into cylinders, ensure that only appropriate refrigerant recovery cylinders are employed. Ensure that the correct number of cylinders for holding the total system charge is available. All cylinders to be used are designated for the recovered refrigerant and labeled for that refrigerant (i.e. special cylinders for the recovery of refrigerant). Cylinders shall be complete with pressure-relief valves and associated shut-off valves in good working order. Empty recovery cylinders are evacuated and, if possible, cooled before recovery occurs.
 - The recovery equipment shall be in good working order with a set of instructions concerning the equipment that is at hand and shall be suitable for the recovery of the refrigerant R290. In addition, a set of calibrated weighing scales shall be available and in good working order. Hoses shall be complete with leak-free disconnect couplings and in good condition. Before using the recovery equipment, check it to ensure it is in good condition and has been properly maintained. All electrical components shall be sealed to prevent potential fires in case of refrigerant leaks. Consult the manufacturer if in doubt.
 - The recovered refrigerant shall be returned to the refrigerant manufacturer in suitable recovery cylinders with transportation instructions. Do not mix refrigerants in recovery units, especially not in cylinders.
 - If compressors or compressor oils are to be removed, ensure that they have been evacuated to an acceptable level to make certain that refrigerant R290 does not remain within the lubricant. Evacuation shall be performed before returning the compressor to the supplier. Only electric heating methods shall be used to heat the compressor body to accelerate this process. Draining of oil from a system shall be carried out safely.



請記錄下列產品資料

型號 Model No.:

機身編號 Serial No.:

經銷商名稱 Dealer:

購買日期 Date of Purchase:

單據編號 Invoice No.:

本產品不斷改進中，如功能有所更改，恕不另行通知
如有疑問，請與客戶服務中心聯絡。不便之處，敬請原諒。
The product specifications may be changed without prior notice.
Please contact customer service for details if necessary.

說明書內容以英文版本為準
If there is any inconsistency or ambiguity
between the English version and the Chinese version,
the English version shall prevail.



保養登記 Warranty Registration

於網上登記新產品保養 Register your product online
www.dchtoolbox.com



客戶服務中心 DCH ToolBox Customer Service Centre
香港九龍灣啓祥道20號大昌行集團大廈4樓
4/F, DCH Building, 20 Kai Cheung Road, Kowloon Bay, Hong Kong

客戶服務熱線 Customer Service Hotline: (852) 8210 8210
電郵地址 E-mail: 8210service@gilman-group.com
網址 Website: www.gilman-group.com